

Agilent 6000 Series Oscilloscopes

Service Guide



Agilent Technologies

Notices

© Agilent Technologies, Inc. 2005-2006

No part of this manual may be reproduced in any form or by any means (including electronic storage and retrieval or translation into a foreign language) without prior agreement and written consent from Agilent Technologies, Inc. as governed by United States and international copyright laws.

Manual Part Number

54684-97010, June 2006

Edition

54684-97001 February 2005
54684-97003 April 2005
54684-97010 May 2006
54684-97008, January 2006
54684-97010, May 2006

Printed in Malaysia

Agilent Technologies, Inc.
1900 Garden of the Gods Road
Colorado Springs, CO 80907 USA

Microsoft[®] is a U.S. registered trademark of Microsoft Corporation.

Warranty

The material contained in this document is provided “as is,” and is subject to being changed, without notice, in future editions. Further, to the maximum extent permitted by applicable law, Agilent disclaims all warranties, either express or implied, with regard to this manual and any information contained herein, including but not limited to the implied warranties of merchantability and fitness for a particular purpose. Agilent shall not be liable for errors or for incidental or consequential damages in connection with the furnishing, use, or performance of this document or of any information contained herein. Should Agilent and the user have a separate written agreement with warranty terms covering the material in this document that conflict with these terms, the warranty terms in the separate agreement shall control.

Technology Licenses

The hardware and/or software described in this document are furnished under a license and may be used or copied only in accordance with the terms of such license.

Restricted Rights Legend

If software is for use in the performance of a U.S. Government prime contract or subcontract, Software is delivered and licensed as “Commercial computer software” as defined in DFAR 252.227-7014 (June 1995), or as a “commercial item” as defined in FAR 2.101(a) or as “Restricted computer software” as defined in FAR 52.227-19 (June 1987) or any equivalent agency regulation or contract clause. Use, duplication or disclosure of Software is subject to Agilent Technologies’ standard commercial license terms, and non-DOD Departments and Agencies of the U.S. Government will receive no greater than Restricted Rights as

defined in FAR 52.227-19(c)(1-2) (June 1987). U.S. Government users will receive no greater than Limited Rights as defined in FAR 52.227-14 (June 1987) or DFAR 252.227-7015 (b)(2) (November 1995), as applicable in any technical data.

Safety Notices

CAUTION

A **CAUTION** notice denotes a hazard. It calls attention to an operating procedure, practice, or the like that, if not correctly performed or adhered to, could result in damage to the product or loss of important data. Do not proceed beyond a **CAUTION** notice until the indicated conditions are fully understood and met.

WARNING

A **WARNING** notice denotes a hazard. It calls attention to an operating procedure, practice, or the like that, if not correctly performed or adhered to, could result in personal injury or death. Do not proceed beyond a **WARNING** notice until the indicated conditions are fully understood and met.

In This Service Guide

This book provides the service information for the Agilent 6000 Series Oscilloscopes. This manual is divided into these chapters:

1 Characteristics and Specifications

This chapter lists characteristics and specifications for the Agilent 6000 Series Oscilloscopes.

2 Testing Performance

This chapter explains how to verify correct oscilloscope operation and perform tests to ensure that the oscilloscope meets the performance specifications.

3 Calibrating and Adjusting

This chapter explains how to adjust the oscilloscope for optimum operating performance.

4 Troubleshooting

This chapter begins with suggestions for solving general problems that you may encounter with the oscilloscope. Procedures for troubleshooting the oscilloscope follow the problem solving suggestions.

5 Replacing Assemblies

This chapter describes how to remove assemblies from the oscilloscope.

6 Replaceable Parts

This chapter describes how to order replaceable assemblies and parts for the Agilent 6000 Series Oscilloscopes. It includes diagrams and parts lists for hardware that you can order.

At the back of the book you will find safety information, and document warranties.

Contents

Figures 9

Tables 11

1 Characteristics and Specifications 13

Specifications 14

Characteristics 15

2 Testing Performance 25

List of Test Equipment 26

Fluke MET/CAL Procedures 27

To construct the test connector (Agilent 6000 Series MSO models only) 28

To test digital channels (Agilent 6000 Series MSO models only) 30

To verify digital channel threshold accuracy (6000 Series MSO models only) 31

When to Test 31

What to Test 31

Verifying Test Results 31

To verify voltage measurement accuracy 35

To verify bandwidth 40

To verify horizontal Dt accuracy 45

To verify trigger sensitivity 47

Test Internal Trigger Sensitivity (all models) 49

Test External Trigger Sensitivity (2-channel models) 50

	Test External Trigger Sensitivity (4-channel models)	54
	Agilent 6000 Series Oscilloscopes Performance Test Record	56
3	Calibrating and Adjusting	59
	User Calibration	61
	To perform User Cal	61
	User Cal Status	64
4	Troubleshooting	65
	Solving General Problems with the Oscilloscope	66
	Troubleshooting the Oscilloscope	69
	Equipment required for troubleshooting	70
	To check out the oscilloscope	70
	To verify basic oscilloscope operation	71
	To compensate the analog probes	73
	To use the troubleshooting flowcharts	73
	To check the power supply	78
	To check the system board	80
	To check the display	81
	To check the fan	82
	To run the internal self-tests	83
	To verify default setup	83
5	Replacing Assemblies	85
	To remove the cabinet	87
	To remove the handle	88
	To remove the storage lid	89
	To remove the front panel assembly	90
	To remove the keyboard assembly	93
	To remove the display assembly	96

To remove the backlight inverter board and e-field shield	100
To remove the LCD, gasket, and protective lens from the display mount	104
To remove the power supply shield	107
To remove the power supply	111
To remove the power shaft	112
To remove the AC input board	113
To remove the fan	114
To remove the system board	116
6 Replaceable Parts	121
Ordering Replaceable Parts	122
Listed Parts	122
Unlisted Parts	122
Direct Mail Order System	122
Exchange Assemblies	123
Exploded Views	124
Replaceable Parts List	126
Index	133

Contents

Figures

- Figure 1. Constructing the 8-by-2 Connector 29
- Figure 2. Setting Up Equipment and Test Connector for the Threshold Test 33
- Figure 3. Connect equipment 38
- Figure 4. Using a Blocking Capacitor to Reduce Noise 39
- Figure 5. Connect equipment 42
- Figure 6. User Calibration cable for 2-channel oscilloscope 62
- Figure 7. User Calibration cable for 4-channel oscilloscope 63
- Figure 8. Start up sequence 71
- Figure 9. Example pulses 73
- Figure 10. Troubleshooting main flow 74
- Figure 11. Troubleshooting power (see also [“To check the power supply”](#) on page 78) 75
- Figure 12. Troubleshooting the system board (see also [“To check the system board”](#) on page 80) 76
- Figure 13. Troubleshooting the display (see also [“To check the display”](#) on page 81) 77
- Figure 14. Power Supply Test Points 79
- Figure 15. Location of the Fan Connector 82
- Figure 16. Default setup screen 84
- Figure 17. Removing the cabinet 87
- Figure 18. Removing handle 88
- Figure 19. Installing the hinged storage lid 89
- Figure 20. Removing the intensity knob and T6 screws 90
- Figure 21. Disconnecting ribbon cable and releasing tab retainers 91
- Figure 22. Removing the front panel 91
- Figure 23. Removing the keyboard assembly 94

Figures

- Figure 24. Removing the main shield and disconnecting the display cables 97
- Figure 25. Removing the display assembly 98
- Figure 26. Installing the display 99
- Figure 27. Opening the backlight inverter shield 100
- Figure 28. Removing the backlight inverter 101
- Figure 29. Removing the backlight inverter shield 102
- Figure 30. Closing the shield 103
- Figure 31. Release display mount latches 104
- Figure 32. Removing the LCD, gasket, and protective lens 105
- Figure 33. Latch over face of sheetmetal housing 106
- Figure 34. Release hook legs from deck. 107
- Figure 35. Dielectric insulator tape. 108
- Figure 36. Proper angles for tabs and hook legs. 109
- Figure 37. Tilt to insert tabs. 109
- Figure 38. Insert hook legs and lock in place. 110
- Figure 39. Removing the power supply 111
- Figure 40. Removing the power shaft latch 112
- Figure 41. Removing the AC input board 113
- Figure 42. Removing main shield and disconnecting fan cable. 114
- Figure 43. Removing the fan 115
- Figure 44. Preparing to remove the system board 117
- Figure 45. Removing the system board 118
- Figure 46. Exploded View 1 of 2 124
- Figure 47. Exploded View 2 of 2 125

Tables

Table 1. Warranted specifications	14
Table 2. Characteristics	15
Table 3. List of test equipment	26
Table 4. Materials required to construct the test connectors	28
Table 5. Equipment Required to Test Threshold Accuracy	32
Table 6. Threshold Accuracy Voltage Test Settings	34
Table 7. Equipment Required to Verify Voltage Measurement Accuracy	36
Table 8. Settings Used to Verify Voltage Measurement Accuracy	37
Table 9. Equipment Required to Verify Bandwidth	41
Table 10. Equipment Required to Verify Horizontal Dt Accuracy	46
Table 11. Equipment Required to Verify Trigger Sensitivity	48
Table 12. Equipment Required to Troubleshoot the Oscilloscope	70
Table 13. Other voltage probe points	80
Table 14. Display Signals on the System Board – All Oscilloscopes	81
Table 15. Replaceable Parts	126
Table 16. Power Cords	131



1 Characteristics and Specifications

This chapter lists characteristics and specifications for the Agilent 6000 Series Oscilloscopes.



Specifications

All specifications are warranted. Specifications are valid after a 30-minute warm-up period and within $\pm 10^{\circ}\text{C}$ of last “User Cal” temperature.

Table 1 Warranted specifications

Vertical system: scope channels

Bandwidth (–3dB)	MSO/DSO601xA: DC to 100 MHz MSO/DSO603xA: DC to 300 MHz MSO/DSO605xA: DC to 500 MHz MSO/DSO610xA: DC to 1 GHz
DC vertical gain accuracy	$\pm 2.0\%$ full scale
Dual cursor accuracy ¹	$\pm\{\text{DC vertical gain accuracy} + 0.4\% \text{ full scale } (\sim 1 \text{ LSB})\}$ <i>Example:</i> for 50 mV signal, scope set to 10 mV/div (80 mV full scale), 5 mV offset, accuracy = $\pm\{2.0\% (80 \text{ mV}) + 0.4\% (80 \text{ mV})\} = \pm 1.92 \text{ mV}$

Vertical system: logic channels (MSO6000A or MSO-upgraded DSO6000A only)

Threshold accuracy	$\pm(100 \text{ mV} + 3\% \text{ of threshold setting})$
--------------------	--

Scope channel triggering

Sensitivity	$< 10 \text{ mV/div}$: greater of 1 div or 5mV; $\geq 10 \text{ mV/div}$: 0.6 div
-------------	---

Logic (D15 - D0) channel triggering (MSO6000A or MSO-upgraded DSO6000A only)

Threshold accuracy	$\pm(100 \text{ mV} + 3\% \text{ of threshold setting})$
--------------------	--

¹ 1 mV/div is a magnification of 2 mV/div setting for 100 MHz models and 2 mV/div is a magnification of 4 mV/div setting for 300 MHz - 1 GHz models. For vertical accuracy calculations, use full scale of 16 mV for 1 mV/div sensitivity setting and 32 mV for 2 mV/div sensitivity setting.

Characteristics

All characteristics are the typical performance values and are not warranted. Characteristics are valid after a 30-minute warm-up period and within $\pm 10^{\circ}\text{C}$ of last “User Cal” temperature.

Table 2 Characteristics

Acquisition: scope channels

Sample rate	MSO/DSO601xA/603xA: 2 GSa/sec each channel MSO/DSO605xA/610xA: 4 GSa/sec half channel*, 2 GSa/sec each channel
Standard memory depth	With logic channels turned off, 1 Mpts half channel*, 500 kpts each channel With logic channels turned on, 625 kpts half channel*, 312 kpts each channel
Optional memory depth	With logic channels turned off, Option 2ML or 2MH – 2 Mpts half channel*, 1 Mpts each channel Option 8ML or 8MH – 8 Mpts half channel*, 4 Mpts each channel With logic channels turned on, Option 2ML or 2MH – 1.25 Mpts half channel*, 625 kpts each channel Option 8ML or 8MH – 5 Mpts half channel*, 2.5 Mpts each channel
Vertical resolution	8 bits
Peak detection	MSO/DSO601xA: 1-ns peak detect MSO/DSO603xA: 500-ps peak detect MSO/DSO605xA/610xA: 250-ps peak detect
Averaging	Selectable from 2, 4, 8, 16, 32, 64 ... to 65536
High resolution mode	Average mode with #avg = 1 12 bits of resolution when $\geq 10 \mu\text{s}/\text{div}$, at 4 GSa/s or $\geq 20 \mu\text{s}/\text{div}$, at 2 GSa/s
Filter	Sin x/x interpolation (single shot BW = sample rate/4 or bandwidth of scope, whichever is less) with vectors on and in real-time mode

* Half channel is when only one of channel 1 or 2 is turned on, or only channel 3 or 4 is turned on.

1 Characteristics and Specifications

Acquisition: logic channels (MSO6000A or MSO-upgraded DSO6000A only)

Sample rate	2 GSa/sec one pod, 1 GSa/sec each pod
Maximum input frequency	250 MHz
Standard memory depth	With scope channels turned off, 1 Mpts one pod, 500 kpts each pod With scope channels turned on, 312 kpts one pod, 156 kpts each pod
Optional memory depth	With scope channels turned off, Option 2ML or 2MH – 2 Mpts one pod, 1 Mpts each pod Option 8ML or 8MH – 8 Mpts one pod, 4 Mpts each pod With scope channels turned on, Option 2ML or 2MH – 625 kpts one pod, 312 kpts each pod Option 8ML or 8MH – 2.5 Mpts one pod, 1.25 Mpts each pod
Vertical resolution	1 bit
Glitch detection	2 ns (min pulse width)

Vertical system: scope channels

Scope channels	MSO/DSO6xx2A: Ch 1 and 2 simultaneous acquisition MSO/DSO6xx4A: Ch 1, 2, 3 and 4 simultaneous acquisition
AC coupled	MSO/DSO601xA: 3.5 Hz to 100 MHz MSO/DSO603xA: 3.5 Hz to 300 MHz MSO/DSO605xA: 3.5 Hz to 500 MHz MSO/DSO610xA: 3.5 Hz to 1 GHz
Calculated rise time (= 0.35/bandwidth)	MSO/DSO601xA: 3.5 nsec MSO/DSO603xA: 1.17 nsec MSO/DSO605xA: 700 psec MSO/DSO610xA: 350 psec
Single-shot bandwidth	MSO/DSO601xA: 100 MHz MSO/DSO603xA: 300 MHz MSO/DSO605xA: 500 MHz MSO/DSO610xA: 1 GHz (in half-channel mode)
Range ¹	MSO/DSO601xA: 1 mV/div to 5 V/div (1 M Ω) MSO/DSO603xA and MSO/DSO605xA: 2 mV/div to 5 V/div (1 M Ω or 50 Ω) MSO/DSO610xA: 2 mV/div to 5 V/div (1 M Ω), 2 mV/div to 1 V/div (50 Ω)
Maximum input	 CAT I 300 Vrms, 400 Vpk; transient overvoltage 1.6 kVpk CAT II 100 Vrms, 400 Vpk With 10073C 10:1 probe: CAT I 500 Vpk, CAT II 400 Vpk
Offset range	± 5 V on ranges <10 mV/div; ± 20 V on ranges 10 mV/div to 200 mV/div; ± 75 V on ranges >200 mV/div

¹ 1 mV/div is a magnification of 2 mV/div setting for 100 MHz models and 2 mV/div is a magnification of 4 mV/div setting for 300 MHz - 1 GHz models. For vertical accuracy calculations, use full scale of 16 mV for 1 mV/div sensitivity setting and 32 mV for 2 mV/div sensitivity setting.

Vertical system: scope channels (continued)

Dynamic range	±8 div
Input impedance	MSO/DSO601xA: 1 MΩ ± 1% 11 pF MSO/DSO603xA/605xA/610xA: 1 MΩ ± 1% 14 pF or 50 Ω ± 1.5%, selectable
Coupling	AC, DC
BW limit	25 MHz selectable
Channel-to-channel isolation	DC to max bandwidth >40 dB
Standard probes	MSO/DSO601xA: 10:1 10074C shipped standard for each scope channel MSO/DSO603xA/605xA/610xA: 10:1 10073C shipped standard for each scope channel
Probe ID	MSO/DSO601xA: Auto probe sense MSO/DSO603xA/605xA/610xA: Auto probe sense and AutoProbe interface Agilent- and Tektronix-compatible passive probe sense
ESD tolerance	±2 kV
Noise peak-to-peak	MSO/DSO601xA: 3% full scale or 2 mV, whichever is greater MSO/DSO603xA: 3% full scale or 3 mV, whichever is greater MSO/DSO605xA: 3% full scale or 3.6 mV, whichever is greater MSO/DSO610xA: 3% full scale or 4 mV, whichever is greater
DC vertical offset accuracy	≤ 200 mV/div: ±0.1 div ±2.0 mV ±0.5% offset value; >200 mV/div: ±0.1 div ±2.0 mV ±1.5% offset value
Single cursor accuracy ¹	±{DC vertical gain accuracy + DC vertical offset accuracy + 0.2% full scale (~1/2 LSB)} <i>Example:</i> for 50 mV signal, scope set to 10 mV/div (80 mV full scale), 5 mV offset, accuracy = ±{2.0% (80 mV) + 0.1 (10 mV) + 2.0 mV + 0.5% (5 mV) + 0.2%(80 mV)} = ± 4.785 mV

Vertical system: logic channels (MSO6000A or MSO-upgraded DSO6000A only)

Number of channels	16 logic timing channels – labeled D15 - D0
Threshold groupings	Pod 1: D7 - D0 Pod 2: D15 - D8
Threshold selections	TTL, CMOS, ECL and user-definable (selectable by pod)
User-defined threshold range	±8.0 V in 10 mV increments
Maximum input voltage	±40 V peak CAT I; transient overvoltage 800 Vpk
Input dynamic range	±10 V about threshold
Minimum input voltage swing	500 mV peak-to-peak
Input capacitance	~8 pF
Input resistance	100 kΩ ±2% at probe tip
Channel-to-channel skew	2 ns typical, 3 ns maximum

¹ 1 mV/div is a magnification of 2 mV/div setting for 100 MHz models and 2 mV/div is a magnification of 4 mV/div setting for 300 MHz - 1 GHz models. For vertical accuracy calculations, use full scale of 16 mV for 1 mV/div sensitivity setting and 32 mV for 2 mV/div sensitivity setting.

1 Characteristics and Specifications

Horizontal

Range	MSO/DSO601xA: 5 nsec/div to 50 sec/div MSO/DSO603xA: 2 nsec/div to 50 sec/div MSO/DSO605xA: 1 nsec/div to 50 sec/div MSO/DSO610xA: 500 psec/div to 50 sec/div
Resolution	2.5 psec
Timebase accuracy	15 ppm ($\pm 0.0015\%$)
Vernier	1-2-5 increments when off, ~25 minor increments between major settings when on
Delay range	Pre-trigger (negative delay): Greater of 1 screen width or 1 ms (with 8 Mpts memory option) Greater of 1 screen width or 250 μ s (with 2 Mpts memory option) Greater of 1 screen width or 125 μ s (with standard memory) Post-trigger (positive delay): 1 s - 500 seconds
Analog delta-t accuracy	Same channel: $\pm 0.0015\%$ reading $\pm 0.1\%$ screen width ± 20 ps Channel-to-channel: $\pm 0.0015\%$ reading $\pm 0.1\%$ screen width ± 40 ps <i>Same channel example (MSO/DSO605xA):</i> For signal with pulse width of 10 μ s, scope set to 5 μ s/div (50 μ s screen width), delta-t accuracy = $\pm\{0.0015\% (10 \mu\text{s}) + 0.1\% (50 \mu\text{s}) + 20 \text{ps}\} = 50.17 \text{ns}$
Logic delta-t accuracy	Same channel: $\pm 0.005\%$ reading $\pm 0.1\%$ screen width $\pm(1$ logic sample period, 1 ns) Channel-to-channel: $\pm 0.005\%$ reading $\pm 0.1\%$ screen width $\pm(1$ logic sample period) \pm chan-to-chan skew <i>Same channel example:</i> For signal with pulse width of 10 μ s, scope set to 5 μ s/div (50 μ s screen width), delta-t accuracy = $\pm\{0.005\% (10 \mu\text{s}) + 0.1\% (50 \mu\text{s}) + 1 \text{ns}\} = 51.5 \text{ns}$
Modes	Main, delayed, roll, XY
XY	Bandwidth: Max bandwidth Phase error @ 1 MHz: <0.5 degrees Z Blanking: 1.4 V blanks trace (use external trigger on MSO/DSO6xx2A, channel 4 on MSO/DSO6xx4A)
Reference positions	Left, center, right

Trigger system

Sources	MSO6xx2A: Ch 1, 2, line, ext, D15 - D0 DSO6xx2A h 1, 2, line, ext MSO6xx4A: Ch 1, 2, 3, 4, line, ext, D15 - D0 DSO6xx4A: Ch 1, 2, 3, 4, line, ext
Modes	Auto, Normal (triggered), single
Holdoff time	~60 ns to 10 seconds
Trigger jitter	15 ps rms

Trigger system (continued)

Selections	Edge, pulse width, pattern, TV, duration, sequence, CAN, LIN, USB, I ² C, SPI
Edge	Trigger on a rising, falling, alternating or either edge of any source
Pattern	<p>Trigger at the beginning of a pattern of high, low, and don't care levels and/or a rising or falling edge established across any of the analog and digital channels, but only after a pattern has been established for a minimum of 2 nsec.</p> <p>The scope channel's high or low level is defined by that channel's trigger level. The logic channel's trigger level is defined by the threshold for the pod, 0 - 7 or 8 - 15.</p>
Pulse width	<p>Trigger when a positive- or negative-going pulse is less than, greater than, or within a specified range on any of the source channels.</p> <p>Minimum pulse width setting:</p> <ul style="list-style-type: none"> 5 ns (MSO/DSO601xA/603xA scope channels) 2 ns (MSO/DSO605xA/610xA scope channels) 2 ns (logic channels on MSO6000A or MSO-upgraded DSO6000A) <p>Maximum pulse width setting: 10 s</p>
TV	<p>Trigger using any scope channel on most analog progressive and interlaced video standards including HDTV/EDTV, NTSC, PAL, PAL-M or SECAM broadcast standards. Select either positive or negative sync pulse polarity. Modes supported include Field 1, Field 2, all fields, all lines, or any line within a field. TV trigger sensitivity: 0.5 division of sync signal. Trigger holdoff time can be adjusted in half field increments.</p>
Sequence	Arm on event A, trigger on event B, with option to reset on event C or time delay.
CAN	<p>Trigger on CAN (Controller Area Network) version 2.0A and 2.0B signals. Trigger on the start of frame (SOF) bit (standard). N5424A option supports triggering on remote frame ID (RTR), data frame ID (~RTR), remote or data frame ID, data frame ID and data, error frame, all errors, acknowledge error and overload frame.</p>
LIN	<p>Trigger on LIN (Local Interconnect Network) sync break at beginning of message frame (standard). N5424A option supports triggering on frame ID.</p>
USB	<p>Trigger on USB (Universal Serial Bus) start of packet, end of packet, reset complete, enter suspend, or exit suspend on the differential USB data lines. USB low speed and full speed are supported.</p>
I ² C	<p>Trigger on I²C (Inter-IC bus) serial protocol at a start/stop condition or user defined frame with address and/or data values. Also trigger on missing acknowledge, restart, EEPROM read, and 10-bit write.</p>
SPI	<p>Trigger on SPI (Serial Protocol Interface) data pattern during a specific framing period. Supports positive and negative Chip Select framing as well as clock Idle framing and user-specified number of bits per frame.</p>

1 Characteristics and Specifications

Duration	Trigger on a multi-channel pattern whose time duration is less than a value, greater than a value, greater than a time value with a timeout, or inside or outside of a set of time values. Minimum duration setting: 2 ns Maximum duration setting: 10 s
----------	--

Trigger system (continued)

Autoscale	Finds and displays all active scope and logic (for MSO6000A series MSO) channels, sets edge trigger mode on highest-numbered channel, sets vertical sensitivity on scope channels and thresholds on logic channels, time base to display ~1.8 periods. Requires minimum voltage >10 mVpp, 0.5% duty cycle and minimum frequency >50 Hz.
-----------	---

Scope channel triggering

Range (internal)	±6 div from center screen
Coupling	AC (~3.5 Hz on MSO/DSO601xA, ~10 Hz on MSO/DSO603xA/605xA/610xA), DC, noise reject, HF reject and LF reject (~50 kHz)

Logic (D15 - D0) channel triggering (MSO6000A or MSO-upgraded DSO6000A only)

Threshold range (user defined)	±8.0 V in 10 mV increments
Predefined thresholds	TTL = 1.4 V, CMOS = 2.5 V, ECL = -1.3 V

	MSO/DSO6xx2A (2-/2+16-ch models)	MSO/DSO6xx4A (4-/4+16-ch models)
External (EXT) triggering		
Input impedance	MSO/DSO6012A: 1 MΩ ±3% 11 pF or 50 Ω MSO/DSO6032A/6052A/6102A: 1 MΩ ±3% 14 pF or 50 Ω	MSO/DSO6014A: 1.015 kΩ ±5% MSO/DSO6034A/6054A/ 6104A: 2.14 kΩ ±5%
Maximum input	 CAT I 300 Vrms, 400 Vpk, CAT II 100 Vrms, 400 Vpk With 10073C 10:1 probe: CAT I 500 Vpk, CAT II 400 Vpk 5 Vrms with 50-ohm input	±15 V
Range	DC coupling: trigger level ± 1V and ± 8V	±5 V

Sensitivity	For $\pm 1\text{V}$ range setting: DC to 100 MHz, 100 mV; MSO/DSO6032A/6052A/6102A >100 MHz to bandwidth of oscilloscope: 200 mV For $\pm 8\text{V}$ range setting: DC to 100 MHz, 250 mV; MSO/DSO6032A/6052A/6102A >100 MHz to bandwidth of oscilloscope: 500 mV	MSO/DSO6014A: DC to 100 MHz: 500 mV MSO/DSO6034A/6054A/ 6104A: DC to 500 MHz: 500 mV
Coupling	AC (~3.5 Hz), DC, noise reject, HF reject and LF reject (~50 kHz)	
Probe ID	MSO/DSO601xA: Auto probe sense MSO/DSO603xA/605xA/610xA: Auto probe sense and AutoProbe interface Agilent- and Tektronix-compatible passive probe sense	
Display system		
Display	6.3-inch (161 mm) diagonal color TFT LCD	
Throughput of scope channels	Up to 100,000 waveforms/sec in real-time mode	
Resolution	XGA – 768 vertical by 1024 horizontal points (screen area); 640 vertical by 1000 horizontal points (waveform area) 256 levels of intensity scale	
Controls	Waveform intensity on front panel. Vectors on/off; infinite persistence on/off, 8 x 10 grid with intensity control	
Built-in help system	Key-specific help (in English) displayed by pressing and holding key or softkey of interest	
Real-time clock	Time and date (user adjustable)	
Measurement features		
Automatic measurements	Measurements are continuously updated. Cursors track last selected measurement.	
Voltage (scope channels only)	Peak-to-peak, maximum, minimum, average, amplitude, top, base, overshoot, preshoot, RMS	
Time	Frequency, period, + width, – width and duty cycle on any channel. Rise time, fall time, X at max Y (time at max volts), X at min Y (time at min volts), delay, and phase on scope channels only.	
Counter	Built-in 5-digit frequency counter on any channel. Counts up to the scope's bandwidth (1 GHz max). The counter resolution can be increased to 8 digits with an external 10 MHz reference.	
Threshold definition	Variable by percent and absolute value; 10%, 50%, 90% default for time measurements	
Cursors	Manually or automatically placed readout of Horizontal (X, ΔX , $1/\Delta X$) and Vertical (Y, ΔY). Additionally logic or scope channels can be displayed as binary or hex values.	

1 Characteristics and Specifications

Waveform math	One function of 1-2, 1x2, FFT, differentiate, integrate. Source of FFT, differentiate, integrate: scope channels 1 or 2, 1-2, 1+2, 1x2.
---------------	--

FFT

Points	Fixed at 1000 points
Source of FFT	Scope channels 1 or 2 (or 3 or 4 on MSO/DSO6xx4A only), 1+2, 1-2, 1*2
Window	Rectangular, flattop, hanning
Noise floor	-50 to -90 dB depending on averaging
Amplitude	Display in dBV, dBm at 50 Ω
Frequency resolution	0.05/time per div
Maximum frequency	50/time per div

Storage

Save/recall	10 setups and traces can be saved and recalled using internal non-volatile memory Optional Secure Environment Mode ensures setups and traces are stored to volatile memory instead of non-volatile memory so data is erased when power is removed Secure Environment Mode is compliant to NISPOM Chapter 8 requirements
Storage type and format	USB 1.1 host ports on front and rear panels Image formats: BMP (8-bit), BMP (24-bit) Data formats: X and Y (time/voltage) values in CSV format Trace/setup formats: Recalled

I/O

Standard ports	USB 2.0 high speed device, two USB 1.1 host ports, 10/100-BaseT LAN, IEEE488.2 GPIB, XGA video output
Max transfer rate	IEEE488.2 GPIB: 500 kbytes/sec USB (USBTMC-USB488): 3.5 Mbytes/sec 100 Mbps LAN (TCP/IP): 1 Mbytes/sec
Printer compatibility	Selected HP Deskjet, Officejet, Laserjet, color Laserjet and HP PCL 3.0 compatible printers

General characteristics

Physical size	35.4 cm wide x 18.8 cm high x 28.2 cm deep (without handle) 39.9 cm wide x 18.8 cm high x 28.2 cm deep (with handle)
Weight	Net: 4.9 kgs (10.8 lbs) Shipping: 9.4 kgs (20.7 lbs)
Probe comp output	Frequency ~1.2 kHz, Amplitude ~2.5 V

Trigger out	When "Triggers" is selected (delay ~17 ns) 0 to 5 V into open circuit 0 to 2.5 V into 50 Ω When "Source Frequency" or "Source Frequency/8" is selected 0 to 580 mV into open circuit 0 to 290 mV into 50 Ω Max frequency output: 350 MHz (in Source Frequency mode when terminated in 50 Ω) 125 MHz (in Source Frequency/8 mode when terminated in 50 Ω)
10 MHz ref in/out	TTL out, 180 mV to 1 V amplitude with 0 to 2 V offset
Kensington lock	Connection on rear panel for security

Power requirements

Line voltage range	~Line 120 W max, 96-144 V/48-440 Hz, 192-288 V/48-66 Hz, automatic selection
Line frequency	50/60 Hz, 100-240 VAC; 440 Hz, 100-132 VAC
Power usage	110 W max

Environmental characteristics

Ambient temperature	Operating -10 °C to +55 °C; non-operating -51 °C to +71 °C
Humidity	Operating 95% RH at 40 °C for 24 hr; non-operating 90% RH at 65 °C for 24 hr
Altitude	Operating to 4,570 m (15,000 ft); non-operating to 15,244 m (50,000 ft)
Vibration	Agilent class B1 and MIL-PRF-28800F; Class 3 random
Shock	Agilent class B1 and MIL-PRF-28800F; (operating 30 g, 1/2 sine, 11-ms duration, 3 shocks/axis along major axis. Total of 18 shocks)
Pollution degree2	Normally only dry non-conductive pollution occurs. Occasionally a temporary conductivity caused by condensation must be expected.
Indoor use	Rated for indoor use only

Other

Measurement categories	CAT I: Mains isolated CAT II: Line voltage in appliance and to wall outlet
Regulatory information	Safety IEC 61010-1:2001 / EN 61010-1:2001 Canada: CSA C22.2 No. 1010.1:1992 UL 61010B-1:2003
Supplementary information	The product herewith complies with the requirements of the Low Voltage Directive 73/23/EEC and the EMC Directive 89/336/EEC, and carries the CE-marking accordingly. The product was tested in a typical configuration with HP/Agilent test systems.

1 Characteristics and Specifications

Product specifications, characteristics, and descriptions in this document are subject to change without notice.

WARNING

Use this instrument only for measurements within its specified measurement categories.

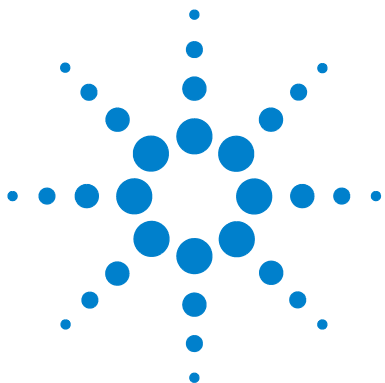

2 Testing Performance

This chapter explains how to verify correct oscilloscope operation and perform tests to ensure that the oscilloscope meets the performance specifications.

To completely test and troubleshoot the mixed-signal oscilloscope, you will create and use a test connector accessory, as described in this chapter.

- The test connector makes it easy for you to connect the oscilloscope probes to function generators and measurement equipment with minimum electrical distortion.
- The connector is used in the digital channel threshold accuracy test.

Let the Equipment Warm Up Before Testing

For accurate test results, let the test equipment and the oscilloscope warm up 30 minutes before testing.

Verifying Test Results

During the tests, record the readings in the Performance Test Record on [page 56](#). To verify whether a test passes, verify that the reading is within the limits in the Performance Test Record.

If a performance test fails

If a performance test fails, first perform the User Cal procedure



List of Test Equipment

Below is a list of test equipment and accessories required to perform the performance test verification procedures.

Table 3 List of test equipment

Equipment	Critical Specifications	Recommended Model/ Part Number
Test connector, 8-by-2	See page 28 for instructions on building test connector.	n/a
Digital Multimeter	0.1 mV resolution, 0.005% accuracy	Agilent 34401A
Power Splitter	Outputs differ by 0.15 dB	Agilent 11667B
Oscilloscope Calibrator	DC offset voltage of -5.5 V to 35.5 V, 0.1 V resolution	Fluke 5820A
Signal Generator	25 MHz, 100 MHz, 300 MHz, 500 MHz, and 1 GHz sine waves	Agilent E4400B or Agilent 8648A
Power Meter/Sensor	1 GHz \pm 3% accuracy	Agilent E4418B/8482A
Oscilloscope Calibrator	25 MHz—500 MHz sine wave, 5 ppm	Fluke 5820A
BNC banana cable		Agilent 11001-60001
BNC cable (qty 3)		Agilent 10503A
Cable	Type N (m) 609.6 mm (24 in.)	Agilent 11500B
Probe cable		Agilent 01650-61607
Shorting Cap BNC		Agilent 1250-0774
Adapter	BNC(f) to banana(m)	Agilent 1251-2277
Adapter	BNC Tee (m) (f) (f)	Agilent 1250-0781
Adapter	Type N (m) to BNC (m)	Agilent 1250-0082
Blocking capacitor		Agilent 10240-60001
Adapter (qty 3)	N(m) to BNC(f)	Agilent 1250-0780
Feedthrough (qty 2)	50 Ω BNC (f) to BNC (m)	Pomona 4119-50

Fluke MET/CAL Procedures

Fluke MET/CAL procedures are available for the 6000 Series oscilloscopes.



The MET/CAL badge with "PROCEDURES AVAILABLE" signifies that Fluke has created Warranted MET/CAL procedures to verify the performance of this instrument using MET/CAL metrology software. These procedures can be obtained from Fluke. Please see <http://www.fluke.com> and search for MET/CAL for more information.

To construct the test connector (Agilent 6000 Series MSO models only)

The Agilent 6000 Series Oscilloscopes have digital channels that you will need to connect to test equipment during testing. To easily connect the digital channels, you will construct a test connector.

Table 4 Materials required to construct the test connectors

Description	Recommended Part	Qty
BNC (f) Connector	Agilent 1250-1032	1
Berg Strip, 8-by-2		1
Jumper wire		

- 1 Obtain a BNC connector and an 8-by-2 section of Berg strip.
- 2 On one side of the Berg strip, solder a jumper wire to all of the pins (shown in [Figure 1](#) on page 29).
- 3 On the other side of the Berg strip, solder another jumper wire to all of the pins.
- 4 Solder the center of the BNC connector to a center pin on one of the rows on the Berg strip.
- 5 Solder the ground tab of the BNC connector to a center pin on the other row on the Berg strip.

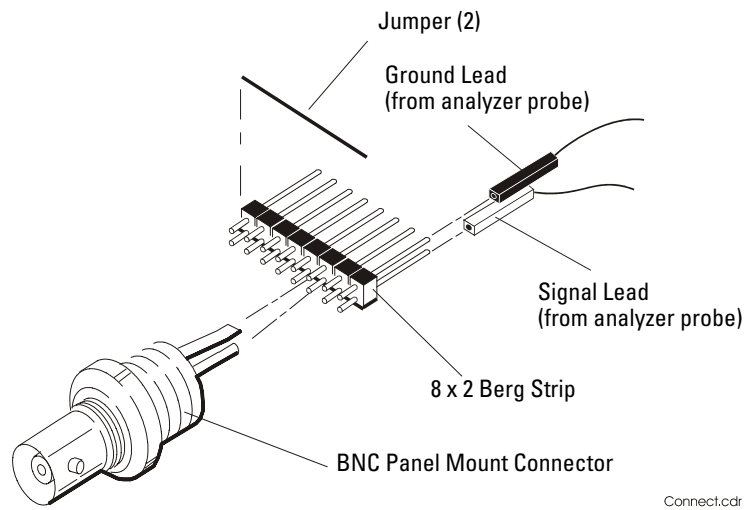

Figure 1 Constructing the 8-by-2 Connector

To test digital channels (Agilent 6000 Series MSO models only)

The acquisition system testing provides confidence that the acquisition system is functioning correctly. It does not, however, check a particular specification.

- 1 Disconnect all probes from the circuit under test and from any other input source.
- 2 Using probe leads and grabbers, connect digital channels D0, D1, D2, and D3 to the Probe Comp signal on the center of the front panel.
- 3 Press the **Autoscale** key.

If four square waves appear, the acquisition system is functioning correctly.

If the square waves do not appear, go to the “Troubleshooting” chapter. Then return here to finish testing the digital channels.

- 4 Disconnect the digital channels from the calibration point.
- 5 Use steps 2 and 3 to test the following sets of digital channels. After you test one set of digital channels, remove them before connecting the next set.
 - D4, D5, D6, D7
 - D8, D9, D10, D11
 - D12, D13, D14, D15

To verify digital channel threshold accuracy (6000 Series MSO models only)

This test verifies the digital channel threshold accuracy specification of the Agilent 6000 Series Oscilloscopes.

Threshold accuracy test limits= $\pm(100 \text{ mV} + 3\% \text{ of threshold setting})$

When to Test

You should perform this test every 12 months or after 2000 hours of operation, whichever comes first.

What to Test

Use these instructions to test the threshold settings of digital channels D7-D0. Then, use the same instructions to test digital channels D15-D8.

Verifying Test Results

After each threshold test, record the voltage reading in the Performance Test Record on [page 56](#). To verify whether a test passes, verify that the voltage reading is within the limits in the Performance Test Record.

Table 5 Equipment Required to Test Threshold Accuracy

Equipment	Critical Specifications	Recommended Model/Part
Digital Multimeter	0.1 mV resolution, 0.005% accuracy	Agilent 34401A
Oscilloscope Calibrator	DC offset voltage 6.3 V	Fluke 5820A
BNC-Banana Cable		Agilent 11001-60001
BNC Tee		Agilent 1250-0781
BNC Cable		Fluke 50Ω cable, P/N 686318
BNC Test Connector, 8-by-2		User-built (See page 28.)
Probe Cable		Agilent 01650-61607

- 1 Turn on the test equipment and the oscilloscope. Let them warm up for 30 minutes before starting the test.
- 2 Set up the oscilloscope calibrator.
 - a Set the oscilloscope calibrator to provide a DC offset voltage at the Channel 1 output.
 - b Use the multimeter to monitor the oscilloscope calibrator DC output voltage.
- 3 Use the 8-by-2 test connector and the BNC cable assembly to connect digital channels D0-D7 to one side of the BNC Tee. Then connect the D0-D7 ground lead to the ground side of the 8-by-2 connector. See [Figure 2](#).

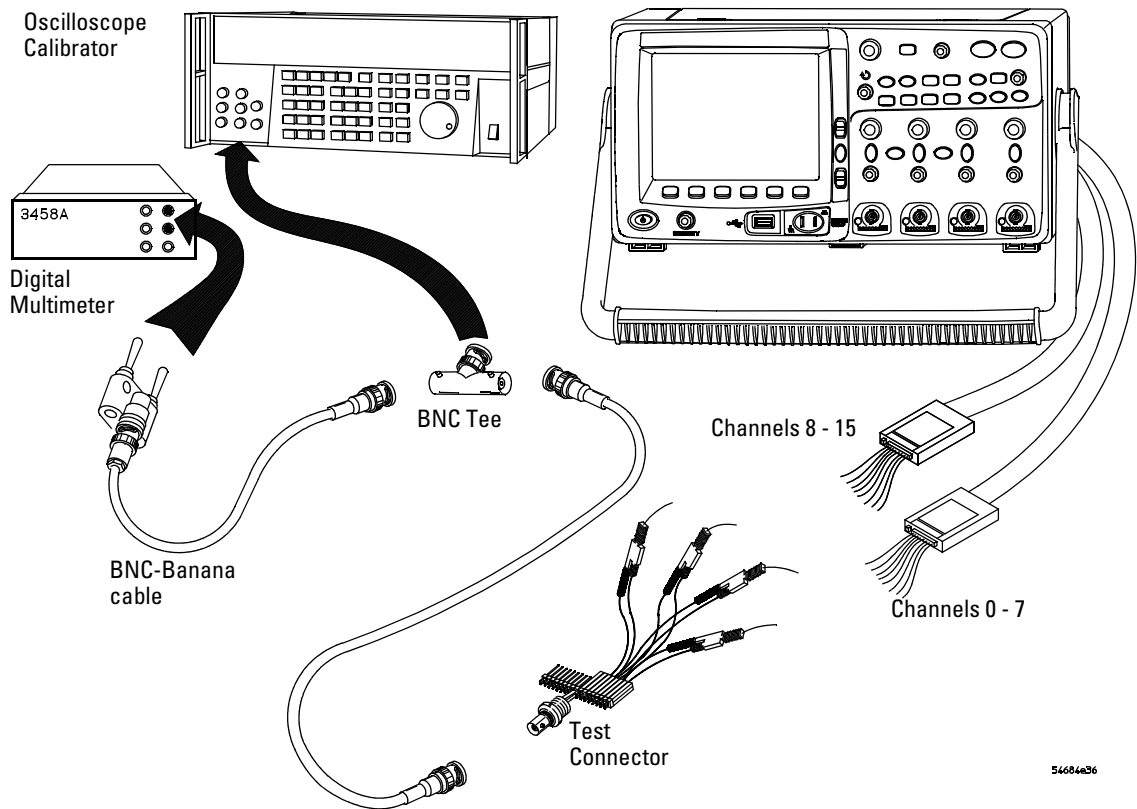

Figure 2 Setting Up Equipment and Test Connector for the Threshold Test

- 4 Use a BNC-banana cable to connect the multimeter to the other side of the BNC Tee.
- 5 Connect the BNC Tee to the Channel 1 output of the calibrator as shown in [Figure 2](#).
- 6 On the oscilloscope, press the **D15 Thru D0** key, then press the **Thresholds** softkey, then press the **D15 Thru D0** softkey repeatedly until the check mark is next to **User**.

- 7 Press the oscilloscope **User** softkey, then turn the Entry knob (↻) on the front panel on the oscilloscope to set the threshold test settings as shown in [Table 6](#).

Table 6 Threshold Accuracy Voltage Test Settings

Threshold voltage setting (in oscilloscope User softkey)	DC offset voltage setting (on oscilloscope calibrator)	Limits
+5.00 V	+5.250 V ±1 mV dc	Lower limit = +4.750 V Upper limit = +5.250 V
-5.00 V	-4.750 V ±1 mV dc	Lower limit = -5.250 V Upper limit = -4.750 V
0.00 V	+100m V ±1 mV dc	Upper limit = +100 mV Lower limit = -100 mV

- 8 Do the following steps for each of the threshold voltage levels shown in [Table 6](#).
- Set the threshold voltage shown in the **User** softkey using the Entry knob on the oscilloscope.
 - Enter the corresponding DC offset voltage on the oscilloscope calibrator front panel. Then use the multimeter to verify the voltage.

Digital channel activity indicators are displayed on the status line at the top of the oscilloscope display. The activity indicators for D7-D0 should show all of the channels at digital high levels.

- Use the knob on the oscilloscope calibrator to decrease the offset voltage, in increments of 10 mV, until the activity indicators for digital channels D7-D0 are all at digital low levels. Record the oscilloscope calibrator voltage in the Performance Test Record ([page 56](#)).
- Use the knob on the oscilloscope calibrator to increase the offset voltage, in increments of 10 mV, until the activity indicators for digital channels D7-D0 are all at digital high

levels. Record the oscilloscope calibrator voltage in the Performance Test Record (page 56).

Before proceeding to the next step, make sure that you have recorded the oscilloscope calibrator voltage levels for each of the threshold settings shown in Table 6.

- 9 Use the 8-by-2 test connector to connect digital channels D15-D8 to the output of the oscilloscope calibrator. Then connect the D15-D8 ground lead to the ground side of the 8-by-2 connector.
- 10 Repeat this procedure (steps 7 and 8) for digital channels D15-D8 to verify threshold accuracy and record the threshold levels in the Performance Test Record (page 56).

To verify voltage measurement accuracy

This test verifies the voltage measurement accuracy. In this test, you will measure the output of a power supply using dual cursors on the oscilloscope, and compare the results with the multimeter reading.

Test limits: $\pm 2.0\%$ of full scale ± 1 LSB*

- On MSO/DSO610xA, MSO/DSO605xA, and MSO/DSO603xA, full scale is defined as 32 mV on the 2 mV/div range.
- On MSO/DSO601xA full scale is defined as 16 mV on the 1 mV/div range.
- Full scale on all other ranges is defined as 8 divisions times the V/div setting.

*1 LSB = 0.4% of full scale

Table 7 Equipment Required to Verify Voltage Measurement Accuracy

Equipment	Critical Specifications	Recommended Model/Part
Oscilloscope Calibrator	14 mV to 35 Vdc, 0.1 V resolution	Fluke 5820A
Digital multimeter	Better than 0.01% accuracy	Agilent 34401A
Cable	BNC, Qty 2	Agilent 10503A
Shorting cap	BNC	Agilent 1250-0774
Adapter	BNC (f) to banana (m)	Agilent 1251-2277
Adapter	BNC tee (m) (f) (f)	Agilent 1250-0781
Blocking capacitor		Agilent 10240B

- 1** Set up the oscilloscope.
 - a** Adjust the channel 1 position knob to place the baseline at 0.5 major division from the bottom of the display.
 - b** Set the Volts/Div setting to the value in the first line in [Table 8](#).

Table 8 Settings Used to Verify Voltage Measurement Accuracy

Volts/Div Setting	Power Supply Setting	Test Limits		
5 V/Div	35 V	34.04 V	to	35.96 V
2 V/Div	14 V	13.616 V	to	14.384 V
1 V/Div	7 V	6.808 V	to	7.192 V
500 mV/Div	3.5 V	3.404 V	to	3.596 V
200 mV/Div	1.4 V	1.3616 V	to	1.4384 V
100 mV/Div	700 mV	680.8 mV	to	719.2 mV
50 mV/Div	350 mV	340.4 mV	to	359.6 mV
20 mV/Div	140 mV	136.16 mV	to	143.84 mV
10 mV/Div	70 mV	68.08 mV	to	71.92 mV
5 mV/Div	35 mV	34.04 mV	to	35.96 mV
2 mV/Div ¹ (for MSO/DSO610xA, MSO/DSO605xA, and MSO/DSO603xA)				
	14 mV	13.232 mV	to	14.768 mV
2 mV/Div (for MSO/DSO601xA)				
	14 mV	13.616 mV	to	14.384 mV
1 mV/Div ²				
	7 mV	6.616 mV	to	7.384 mV

¹ Full scale is defined as 32 mV on the 2 mV/div range for MSO/DSO610xA, MSO/DSO605xA, MSO/DSO603xA.

² Full scale is defined as 16 mV on the 1 mV/div range for MSO/DSO601xA.

Full scale on all other ranges is defined as 8 divisions times the V/div setting.

- c** Press the **Acquire** key. Then press the **Averaging** softkey and set **#Avg**s to 64.

Wait a few seconds for the measurement to settle.

- 2** Press the **Cursors** key, set the **Mode** softkey to **Normal**, then press the **XY** softkey and select **Y**. Press the **Y1** softkey, then use the Entry knob (labeled  on the front panel) to set the Y1 cursor on the baseline of the signal.

2 Testing Performance

- 3 Use the BNC tee and cables to connect the oscilloscope calibrator /power supply to both the oscilloscope and the multimeter (Figure 3).

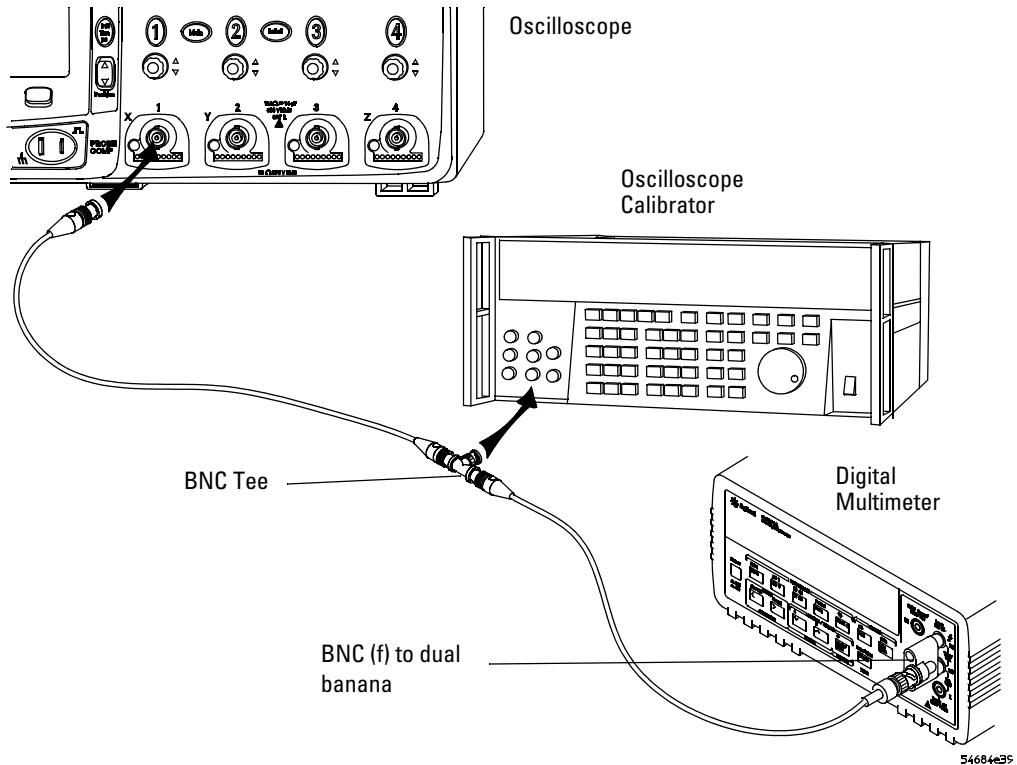

Figure 3 Connect equipment

- 4 Adjust the output so that the multimeter reading displays the first Volts/div supply setting value in Table 8.

Wait a few seconds for the measurement to settle.

- 5 Press the **Y2** softkey, then position the Y2 cursor to the center of the voltage trace using the Entry knob.

The ΔY value on the lower line of the display should be within the test limits of [Table 8](#). If a result is not within the test limits, go to the “Troubleshooting” chapter. Then return here.

- 6 Continue to check the voltage measurement accuracy with the remaining Volts/div setting values in [Table 8](#).
- 7 When you are finished checking all of the power supply setting values, disconnect the power supply from the oscilloscope.
- 8 Repeat this procedure for the remaining channels to be tested.

Use a Blocking Capacitor to Reduce Noise

On the more sensitive ranges, such as 2 mV/div and 5 mV/div, noise may be a factor. To eliminate the noise, use a BNC Tee, blocking capacitor, and BNC shorting cap to shunt the noise to ground. See [Figure 4](#).

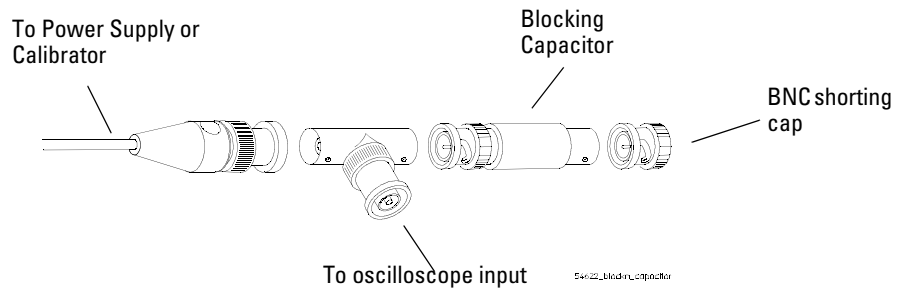

Figure 4 Using a Blocking Capacitor to Reduce Noise

To verify bandwidth

This test checks the bandwidth of the oscilloscope. In this test you will use a signal generator and a power meter.

MSO/DS06102A and MSO/DS06104A

Test limits at 2 mV/div to 5 V/div

- All channels (± 3 dB)
 - dc to 1 GHz
 - ac coupled 3.5 Hz to 1 GHz

MSO/DS06052A and MSO/DS06054A

Test limits at 2 mV/div to 5 V/div

- All channels (± 3 dB)
 - dc to 500 MHz
 - ac coupled 3.5 Hz to 500 MHz

MSO/DS06032A and MSO/DS06034A

Test limits at 2 mV/div to 5 V/div

- All channels (± 3 dB)
 - dc to 300 MHz
 - ac coupled 3.5 Hz to 300 MHz

MSO/DS06012A and MSO/DS06014A

Test limits at 1 mV/div to 5 V/div

- All channels (± 3 dB)
 - dc to 100 MHz
 - ac coupled 3.5 Hz to 100 MHz

Table 9 Equipment Required to Verify Bandwidth

Equipment	Critical Specifications	Recommended Model/Part
Signal Generator	100k - 1 GHz at 200 mVrms	Agilent E4400B/8648A
Power Meter/Sensor	1 - 1 GHz $\pm 3\%$ accuracy	Agilent E4418B/8482A
Power Splitter	outputs differ by < 0.15 dB	Agilent 11667A
Cable	Type N (m) 24 inch	Agilent 11500B
Adapter	Type N (m) to BNC (m)	Agilent 1250-0082
Feedthrough	50 Ω BNC (f) to BNC (m)	Pomona 4119-50

- 1** Connect the equipment ([Figure 5](#)).
 - a** Use the N cable to connect the signal generator to the power splitter input.
 - b** Connect the power sensor to one output of the power splitter.
 - c** For oscilloscope models MSO/DSO610xA, MSO/DSO605xA, and MSO/DSO603xA, use an N-to-BNC adapter to connect the other splitter output to the channel 1 input.
 - d** For MSO/DSO601xA oscilloscopes, use an N-to-BNC adapter and 50 Ω feedthrough termination to connect the other splitter output to the channel 1 input on the oscilloscope.

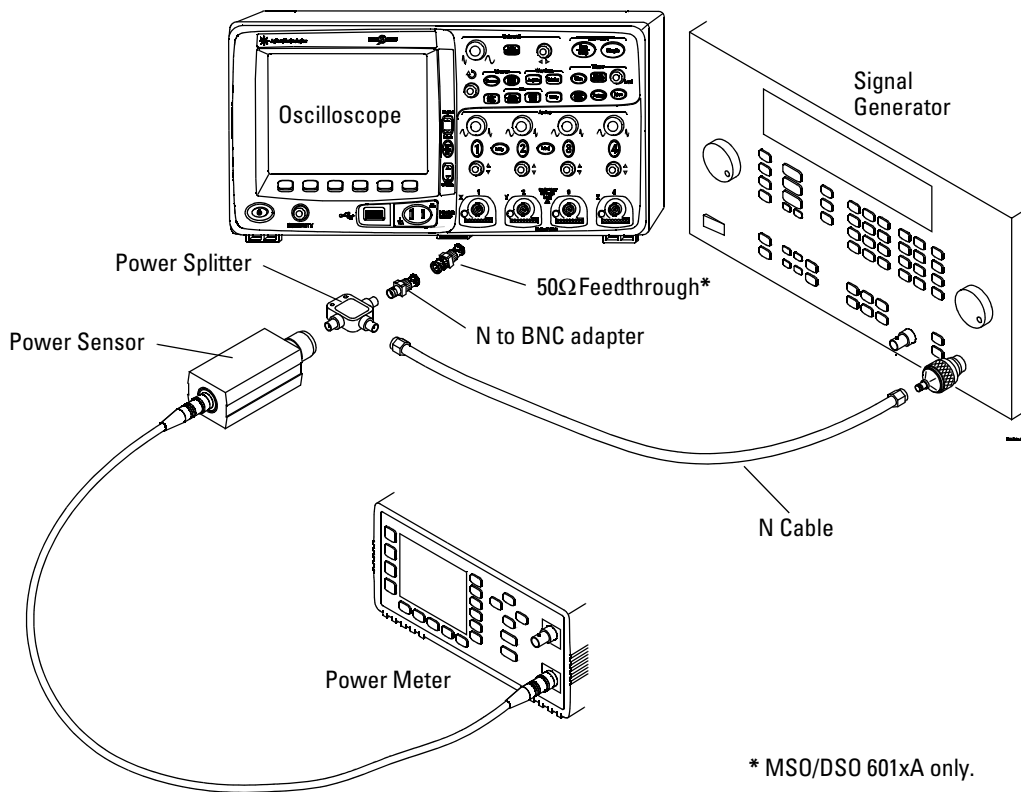

Figure 5 Connect equipment

2 Set up the power meter.

Set the power meter to display measurements in units of watts.

- 3 Set up the oscilloscope.
 - a Press the **Save/Recall** key, then press the **Default Setup** softkey.
 - b Press the **Acquire** key, then press the **Realtime** softkey to unselect Realtime.
 - c Set channel 1 **Coupling** to **DC**.
 - d On MSO/DSO610xA, MSO/DSO605xA, and MSO/DSO603xA models only, set channel 1 **Imped** to **50 Ohm**.
 - e Set the time base to 500 ns/div.
 - f Set the Volts/Div for channel 1 to 200 mV/div.
 - g Press the **Acquire** key, then press the **Averaging** softkey.
 - h Turn the Entry knob to set **# Avgs** to 8 averages.
- 4 Set the signal generator for 1 MHz and six divisions of amplitude.

The signal on the oscilloscope screen should be about five cycles at six divisions amplitude.

- 5 Set up the Amplitude measurement
 - a Press the **Quick Meas** key.
 - b Press the **Clear Meas** softkey.
 - c Press the **Select:** softkey and use the Entry knob to select **Amplitude** within the select menu.
 - d Press the **Measure Ampl** softkey.
- 6 Note the oscilloscope Ampl (1) reading at the bottom of the screen and covert to V_{rms} using the expression:

$$V_{out}_{1MHz} = \frac{Ampl(1)_{1MHz}}{2\sqrt{2}}$$

For example, if the oscilloscope Ampl reading is 595 mV, then $V_{out}_{1MHz} = 595 * 10^{-3} / 2 * (2)^{1/2} = 210.4 \text{ mV}_{rms}$.

- 7 Set the power meter Cal Factor % to the 1 MHz value on the calibration chart on the power sensor.

- 8** Note the reading on the power meter and convert to V_{rms} using the expression:

$$V_{in\ 1MHz} = \sqrt{P_{meas\ 1MHz} \times 50\Omega}$$

For example, if the power meter reading is 892 μ W, then $V_{in\ 1MHz} = (892 \times 10^{-6} \times 50\Omega)^{1/2} = 211.2\ mV_{rms}$.

- 9** Change the signal generator output frequency according to the maximum frequency for the oscilloscope using the following:

- MSO/DSO6102A and MSO/DSO6104A; 1 GHz
- MSO/DSO6052A and MSO/DSO6054A; 500 MHz
- MSO/DSO6032A and MSO/DSO6034A; 300 MHz
- MSO/DSO6012A and MSO/DSO6014A; 100 MHz

- 10** Referencing the frequency from step 9, set the power meter Cal Factor % to the frequency value on the calibration chart on the power sensor.

- 11** Set the oscilloscope sweep speed according to the following:

- MSO/DSO6102A and MSO/DSO6104A; 500 ps/div
- MSO/DSO6052A and MSO/DSO6054A; 1 ns/div
- MSO/DSO6032A and MSO/DSO6034A; 2 ns/div
- MSO/DSO6012A and MSO/DSO6014A; 5 ns/div

- 12** Note the oscilloscope Ampl (1) reading at the bottom of the screen and convert to V_{rms} using the expression:

$$V_{out\ max\ freq} = \frac{Ampl(1)_{max\ freq}}{2\sqrt{2}}$$

- 13** Note the reading on the power meter and convert to V_{rms} using the expression:

$$V_{in\ max\ freq} = \sqrt{P_{meas\ max\ freq} \times 50\Omega}$$

- 14** Calculate the response using the expression:

$$response(dB) = 20 \log_{10} \left[\frac{V_{out\ max\ freq} / V_{in\ max\ freq}}{V_{out\ 1MHz} / V_{in\ 1MHz}} \right]$$

Example

If:

$$P_{\text{meas}}_{1\text{ MHz}} = 892 \text{ uW}$$

$$\text{Ampl}(n)_{1\text{ MHz}} = 595 \text{ mV}$$

$$P_{\text{meas}}_{\text{max freq}} = 687 \text{ uW}$$

$$\text{Ampl}(n)_{\text{max freq}} = 457 \text{ mV}$$

Then after converting all four values to Vrms:

$$\text{response(dB)} = 20 \log_{10} \left[\frac{161.6 \text{ mV} / 185.3 \text{ mV}}{210.4 \text{ mV} / 211.2 \text{ mV}} \right] = -1.16 \text{ dB}$$

- 15** The result from step 14 should be between +3.0 dB and -3.0 dB. Record the result in the Performance Test Record (page 56).
- 16** Move the power splitter from the channel 1 to the channel 2 input.
- 17** Turn off the current channel and turn on the next channel using the channel keys.
- 18** Repeat steps 3 through 17 for the remaining channels, setting the parameters of the channel being tested where appropriate.

To verify horizontal Δt accuracy

This test verifies the horizontal Δt accuracy. In this test, you will use the oscilloscope to measure the output of a time mark generator.

Test limits: $\pm 0.0015\%$ of reading $\pm 0.1\%$ of full scale ± 20 ps (same channel)

Table 10 Equipment Required to Verify Horizontal Δt Accuracy

Equipment	Critical Specifications	Recommended Model/Part
Oscilloscope Calibrator	Stability 5 ppm after 1/2 hour	Fluke 5820A
Cable	BNC, 3 feet	Agilent 10503A
Feedthrough	50 Ω BNC (f) to BNC (m)	Pomona 4119-50

- 1 Connect the equipment:
 - a For oscilloscope models MSO/DSO610xA, MSO/DSO605xA, and MSO/DSO603xA, connect the calibrator output to the oscilloscope channel 1 input.
 - b For MSO/DSO601xA oscilloscopes, use a 50 Ω feedthrough termination to connect the calibrator output to the oscilloscope channel 1 input.
- 2 Set up the signal source.
 - 1 Select **Marker** on the oscilloscope calibrator.
 - 2 Set the calibrator for 100 μ s markers (period = 100 μ s).
- 3 Set up the oscilloscope.
 - a Set channel 1 **Coupling** to **DC**.
 - b On MSO/DSO610xA, MSO/DSO605xA, and MSO/DSO603xA models only, set channel 1 **Imped** to **50 Ohm**.
 - c Press the **Display** key, then set the **Vectors** softkey to off.
 - d Press the **Autoscale** key.
 - e Set the time base to 20 μ s/div.
 - f Press the **Main/Delayed** key, then set the **Time Ref** softkey to **Left**.
 - g Adjust the Trigger Level knob to obtain a stable display.
- 4 Press the **Quick Meas** softkey, set the **Source** softkey to **1**, then press **Select** and choose **Period**. Press the **Measure** softkey and measure the following:

Period 100 μ s – The test limits are 99.8 μ s to 100.2 μ s.

If the measurements are not within the test limits, go to the “Troubleshooting” chapter. Then return here.

5 Change the calibrator to 100 ns markers. Change the time base to 20 ns/div. Adjust the trigger level to obtain a stable display.

6 Measure the following. If the measurements are not within the test limits, go to the “Troubleshooting” chapter. Then return here.

Period 100 ns— The test limits are 99.8 ns to 100.2 ns.

7 Change the time base and calibrator markers as follows:

a On MSO/DSO610xA, MSO/DSO605xA, and MSO/DSO603xA, change time base to 2 ns/div and the calibrator to 5 ns markers

b On MSO/DSO601xA, change time base to 5 ns/div and the calibrator to 10 ns markers

8 Make the following measurements. If the measurements are not within the test limits, go to the “Troubleshooting” chapter. Then return here.

a For MSO/DSO610xA, MSO/DSO605xA, and MSO/DSO603xA, period 5 ns – the test limits are 4.96 ns to 5.04 ns.

b For MSO/DSO601xA, period 10 ns – the test limits are 9.93 ns to 10.07 ns.

To verify trigger sensitivity

This test verifies the trigger sensitivity. In this test, you will apply a 25 MHz sine wave to the oscilloscope. You will then decrease the amplitude of the signal to the specified levels, and check to see if the oscilloscope is still triggered. You will then repeat the process at the upper bandwidth limit.

Test limits for:

- Internal trigger on all models:
 - < 10 mV/div (dc to max bandwidth): greater of 1 div or 5 mV_{p-p}; ≥10 mV/div (dc to max bandwidth): 0.6 div
- External trigger on all 2-channel models (DSO/MSO6xx2A):
 - Trigger range: 1.0V
 - DC to 100 MHz: < 100 mV_{p-p}
 - >100 MHz to max bandwidth: < 200 mV_{p-p}
 - Trigger range: 8.0V
 - DC to 100 MHz: < 250 mV_{p-p}
 - >100 MHz to max bandwidth: < 500 mV_{p-p}
- External trigger on 4-channel models:
 - MSO/DSO6104A/6054A/6034A: DC to 500 MHz: < 400 mV_{p-p}
 - MSO/DSO6014A: DC to 100 MHz: < 400 mV_{p-p}

Table 11 Equipment Required to Verify Trigger Sensitivity

Equipment	Critical Specifications	Recommended Model/Part
Signal Generator	25-MHz, 100-MHz, 300-MHz, 500-MHz, and 1 GHz sine waves	Agilent E4400B/8648A
Power splitter	Outputs differ < 0.15 dB	Agilent 11667B
Cable	BNC, Qty 3	Agilent 10503A
Adapter	N (m) to BNC (f), Qty 3	Agilent 1250-0780
Feedthrough	50Ω BNC (f) to BNC (m) Qty 2	Pomona 4119-50

Test Internal Trigger Sensitivity (all models)

- 1 Press the **Save/Recall** key, then press the **Default Setup** softkey.
- 2 Connect the equipment.
 - a For oscilloscope models MSO/DSO610xA, MSO/DSO605xA, and MSO/DSO603xA, connect the signal generator output to the oscilloscope channel 1 input.
 - b For MSO/DSO601xA oscilloscopes, use a 50 Ω feedthrough termination to connect the signal generator output to the oscilloscope channel 1 input.
- 3 Verify the trigger sensitivity at 25 MHz.
 - a Set channel 1 **Coupling** to **DC**.
 - b On MSO/DSO610xA, MSO/DSO605xA, and MSO/DSO603xA models only, set channel 1 **Imped** to **50 Ohm**.
 - c Set the output of the signal generator to 25 MHz and set the amplitude to about 10 mV_{p-p}.
 - d Press the **Autoscale** key.
 - e Set the time base to 10 ns/div.
 - f Set channel 1 to 5 mV/div.
 - g Decrease the output of the signal generator until 1 vertical division of the signal is displayed.

The trigger is stable when the displayed waveform is stable. If the trigger is not stable, try adjusting the trigger level. If adjusting the trigger level makes the trigger stable, the test still passes. If adjusting the trigger does not help, see the "Troubleshooting" chapter. Then return here.
 - h Record the result as Pass or Fail in the Performance Test Record ([page 56](#)).

- 4 Verify the trigger sensitivity at maximum bandwidth.
 - a Change the output frequency of the signal generator according to the following and set the amplitude to about 100 mV_{p-p}.

MSO/DSO6102A and MSO/DSO6104A; 1 GHz
MSO/DSO6052A and MSO/DSO6054A; 500 MHz
MSO/DSO6032A and MSO/DSO6034A; 300 MHz
MSO/DSO6012A and MSO/DSO6014A; 100 MHz
 - b Set the time base as follows:

MSO/DSO610xA; 1 ns/div
MSO/DSO605xA; 1 ns/div
MSO/DSO603xA; 2 ns/div
MSO/DSO601xA; 5 ns/div
 - c Set channel 1 to 100 mV/div.
 - d Decrease the output of the signal generator until 0.6 vertical division of the signal is displayed.

The trigger is stable when the displayed waveform is stable. If the trigger is not stable, try adjusting the trigger level. If adjusting the trigger level makes the trigger stable, the test still passes. If adjusting the trigger does not help, see the "Troubleshooting" chapter. Then return here.
 - e Record the result as Pass or Fail in the Performance Test Record ([page 56](#)).
- 5 Repeat this procedure for the remaining oscilloscope channels.

Test External Trigger Sensitivity (2-channel models)

Verify the external trigger sensitivity at these settings:

Trigger range = +/- 1 V

- 1 GHz (MSO/DSO6102A), < 200 mV_{p-p}
- 500 MHz (MSO/DSO6052A), < 200 mV_{p-p}
- 300 MHz (MSO/DSO6032A), < 200 mV_{p-p}

- 100 MHz (MSO/DSO6012A), < 200 mV_{p-p}
- 25 MHz (All models), < 100 mV_{p-p}

Trigger range = +/- 8 V

- 1 GHz (MSO/DSO6102A), < 500 mV_{p-p}
- 500 MHz (MSO/DSO6052A), < 500 mV_{p-p}
- 300 MHz (MSO/DSO6032A), < 500 mV_{p-p}
- 100 MHz (MSO/DSO6012A), < 500 mV_{p-p}
- 25 MHz (All models), < 250 mV_{p-p}

1 Connect the equipment.

- Connect the signal generator output to the input of the power splitter.
- For oscilloscope models MSO/DSO610xA, MSO/DSO605xA, and MSO/DSO603xA, connect one output of the power splitter to channel 1.
- For MSO/DSO601xA oscilloscopes, use a 50Ω feedthrough termination to connect one output of the power splitter to channel 1.
- For oscilloscope models MSO/DSO610xA, MSO/DSO605xA, and MSO/DSO603xA, connect the other output of the power splitter to the Ext Trig input on the front panel of the oscilloscope.
- For MSO/DSO601xA oscilloscopes, use a 50Ω feedthrough termination to connect the other output of the power splitter to the Ext Trig input on the front panel of the oscilloscope.

- 2 Set up the oscilloscope.
 - a Set channel 1 **Coupling** to **DC**.
 - b On MSO/DSO610xA, MSO/DSO605xA, and MSO/DSO603xA models only, set channel 1 **Imped** to **50 Ohm**.
 - c Press the **Mode/Coupling** key and set **Coupling** to **DC**.
 - d In the Mode/Coupling menu, press the **External** softkey, then press the **Range** softkey and use the Entry knob to set range to 1.0 V.
 - e On MSO/DSO610xA, MSO/DSO605xA, and MSO/DSO603xA models only, press the **Imped** softkey and set impedance to **50 Ohm**.
- 3 Verify the trigger sensitivity at maximum frequency for trigger range of 1.0 V.

- a Change the signal generator output frequency according to the following:

MSO/DSO6102A = 1 GHz

MSO/DSO6052A = 500 MHz

MSO/DSO6032A = 300 MHz

MSO/DSO6012A = 100 MHz

Set channel 1 vertical scale to 50 mV/div and adjust the signal generator output for four divisions of amplitude on the oscilloscope ($200 \text{ mV}_{\text{p-p}}$).

- b Press the **Autoscale** key.
- c Press the Trigger **Edge** key, then press the **Source** softkey to set the trigger source to external trigger.
- d Check for stable triggering and adjust the trigger level if necessary.
- e Record the results as Pass or Fail in the Performance Test Record ([page 56](#)).

If the test fails, see the "Troubleshooting" chapter. Then return here.

- 4** Verify the trigger sensitivity at 25 MHz for trigger range of 1.0 V.
- a** Change the signal generator output frequency to 25 MHz. Set channel 1 vertical scale to 20 mV/div and adjust the signal generator output for five divisions of amplitude on the oscilloscope (100 mV_{p-p}).
 - b** Check for stable triggering and adjust the trigger level if necessary.
 - c** Record the results as Pass or Fail in the Performance Test Record ([page 56](#)).

If the test fails, see the "Troubleshooting" chapter. Then return here.

- 5** Verify the trigger sensitivity at maximum frequency for trigger range of 8.0 V.
- a** Press the **Mode/Coupling** key, press the **External** softkey, then press the **Range** softkey and use the Entry knob to set range to 8.0 V.
 - b** Change the signal generator output frequency according to the following:

MSO/DSO6102A = 1 GHz
 MSO/DSO6052A = 500 MHz
 MSO/DSO6032A = 300 MHz
 MSO/DSO6012A = 100 MHz

Set channel 1 vertical scale to 100 mV/div and adjust the signal generator output for five divisions of amplitude on the oscilloscope (500 mV_{p-p}).

- c** Press the **Autoscale** key.
- d** Press the Trigger **Edge** key, then press the **Source** softkey to set the trigger source to external trigger.
- e** Check for stable triggering and adjust the trigger level if necessary.
- f** Record the results as Pass or Fail in the Performance Test Record ([page 56](#)).

If the test fails, see the "Troubleshooting" chapter. Then return here.

- 6** Verify the trigger sensitivity at 25 MHz for trigger range of 8.0 V.
 - a** Change the signal generator output frequency to 25 MHz. Set channel 1 vertical scale to 50 mV/div and adjust the signal generator output for five divisions of amplitude on the oscilloscope (250 mV_{p-p}).
 - b** Check for stable triggering and adjust the trigger level if necessary.
 - c** Record the results as Pass or Fail in the Performance Test Record ([page 56](#)).

If the test fails, see the "Troubleshooting" chapter. Then return here.

Test External Trigger Sensitivity (4-channel models)

Verify the external trigger sensitivity at these settings:

- 500 MHz (MSO/DSO610xA, MSO/DSO605xA, and MSO/DSO603xA models), < 500 mV_{p-p}
- 100 MHz (MSO/DSO601xA models), < 500 mV_{p-p}

- 1** Connect the equipment.
 - a** With an N-to-BNC adapter and BNC cable, connect the signal generator to the input of the power splitter.
 - b** Connect one output of the power splitter to the Aux Trig input through a 50Ω feedthrough termination.
 - c** For oscilloscope models MSO/DSO610xA, MSO/DSO605xA, and MSO/DSO603xA, connect the other output of the power splitter to channel 1.
 - d** For MSO/DSO601xA oscilloscopes, use a 50Ω feedthrough termination to connect the other output of the power splitter to channel 1.

- 2 Set up the oscilloscope.
 - a Set channel 1 **Coupling** to **DC**.
 - b On MSO/DSO610xA, MSO/DSO605xA, and MSO/DSO603xA models only, set channel 1 **Imped** to **50 Ohm**.
 - c Press the **Mode/Coupling** key and set **Coupling** to **DC**.
- 3 Change output frequency as follows:
 - For oscilloscope models MSO/DSO610xA, MSO/DSO605xA, and MSO/DSO603xA, set the signal generator output frequency to 500 MHz
 - For MSO/DSO601xA oscilloscopes, set the signal generator output frequency to 100 MHz
- 4 Set channel 1 vertical scale to 100 mV/div and adjust the signal generator output for five divisions of amplitude on the oscilloscope (500 mV_{p-p}).
- 5 Press the **Autoscale** key.
- 6 Press the Trigger **Edge** key, then press the **Source** softkey to set the trigger source to **External**.
- 7 Check for stable triggering and adjust the trigger level if necessary.
- 8 Record the results as Pass or Fail in the Performance Test Record ([page 56](#)).

If the test fails, see the "Troubleshooting" chapter. Then return here.

Agilent 6000 Series Oscilloscopes Performance Test Record

Serial No. _____			Test by _____			
Test Interval _____			Work Order No. _____			
Recommended Next Testing _____			Temperature _____			
Threshold	Specification	Limits	Ch D7-D0	Ch D15-D8		
Accuracy Test	5 V - 250 mV	4.750 V	_____	_____		
(100 mV + 3% of threshold setting)	5 V + 250 mV	5.250 V	_____	_____		
	-5 V - 250 mV	-5.250 V	_____	_____		
	-5 V + 250 mV	-4.750 V	_____	_____		
	0 V - 100 mV	-100 mV	_____	_____		
	0 V + 100 mV	100 mV	_____	_____		
Voltage Measurement Accuracy						
Range	Power Supply Setting	Test Limits	Channel 1	Channel 2	Channel 3*	Channel 4*
5 V/Div	35 V	34.04 V to 35.96 V	_____	_____	_____	_____
2 V/Div	14 V	13.616 V to 14.384 V	_____	_____	_____	_____
1 V/Div	7 V	6.808 V to 7.192 V	_____	_____	_____	_____
500 mV/Div	3.5 V	3.404 V to 3.596 V	_____	_____	_____	_____
200 mV/Div	1.4 V	1.3616 V to 1.4384 V	_____	_____	_____	_____
100 mV/Div	700 mV	680.8 mV to 719.2 mV	_____	_____	_____	_____
50 mV/Div	350 mV	340.4 mV to 359.6 mV	_____	_____	_____	_____
20 mV/Div	140 mV	136.16 mV to 143.84 mV	_____	_____	_____	_____
10 mV/Div	70 mV	68.08 mV to 71.92 mV	_____	_____	_____	_____
5 mV/Div	35 mV	34.04 mV to 35.96 mV	_____	_____	_____	_____
2 mV/Div (MSO/DSO610xA, MSO/DSO605xA, and MSO/DSO603xA)	14 mV	13.232 mV to 14.768 mV	_____	_____	_____	_____
2 mV/Div (MSO/DSO601xA)	14 mV	13.616 mV to 14.384 mV	_____	_____	_____	_____
1 mV/Div (MSO/DSO6012A)	7 mV	6.616 mV to 7.384 mV	_____	_____	_____	_____
Bandwidth						
Model	Test Limits	Channel 1	Channel 2	Channel 3*	Channel 4*	
610xA	3 dB at 1 GHz	_____	_____	_____	_____	
605xA	3 dB at 500 MHz	_____	_____	_____	_____	
603xA	3 dB at 300 MHz	_____	_____	_____	_____	
601xA	3 dB at 100 MHz	_____	_____	_____	_____	
Horizontal Δt Accuracy						
	Generator Setting	Test Limits	Results			
Period	100 μ s	99.8 μ s to 100.2 μ s	_____			
Period	100 ns	99.8 ns to 100.2 ns	_____			
Period	10 ns ¹	9.93 ns to 10.07 ns	_____			
Period	5 ns ²	4.96 ns to 5.04 ns	_____			
¹ MSO/DSO601xA						
² MSO/DSO610xA, MSO/DSO605xA, and MSO/DSO603xA						

Trigger Sensitivity	Test Limits	Channel 1	Channel 2	Channel 3*	Channel 4*
Internal trigger					
6102A/6104A	1 division at 25 MHz	_____	_____	_____	_____
6052A/6054A	0.6 division at 1 GHz	_____	_____	_____	_____
6032A/6034A	0.6 division at 500 MHz	_____	_____	_____	_____
6012A/6014A	0.6 division at 300 MHz	_____	_____	_____	_____
	0.6 division at 100 MHz	_____	_____	_____	_____
Trigger Sensitivity	Test Limits	Channel 1	Channel 2	Channel 3*	Channel 4*
External trigger (6102A, 6052A, 6032A, 6012A)					
± 1 V range:					
6102A	100 mV at 25 MHz	_____	_____	_____	_____
6052A	200 mV at 1 GHz	_____	_____	_____	_____
6032A	200 mV at 500 MHz	_____	_____	_____	_____
6012A	200 mV at 300 MHz	_____	_____	_____	_____
	200 mV at 100 MHz	_____	_____	_____	_____
External trigger (6102A, 6052A, 6032A, 6012A)					
± 8 V range:					
6102A	250 mV at 25 MHz	_____	_____	_____	_____
6052A	500 mV at 1 GHz	_____	_____	_____	_____
6032A	500 mV at 500 MHz	_____	_____	_____	_____
6012A	500 mV at 300 MHz	_____	_____	_____	_____
	500 mV at 100 MHz	_____	_____	_____	_____
External trigger (6014A, 6034A, 6054A, 6104A)					
6104A, 6054A, 6034A	500 mV at 500 MHz	_____	_____	_____	_____
6014A	500 mV at 100 MHz	_____	_____	_____	_____

* Where applicable

2 Testing Performance

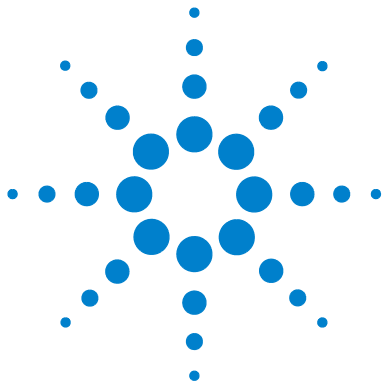

3 Calibrating and Adjusting

This chapter explains how to adjust the oscilloscope for optimum operating performance. You should perform self-calibration according to the following recommendations:

- Every 12 months or after 2000 hours of operation
- If the ambient temperature is >10 °C from the calibration temperature
- If you want to maximize the measurement accuracy

The amount of use, environmental conditions, and experience with other instruments help determine if you need shorter adjustment intervals.

Let the Equipment Warm Up Before Adjusting

Before you start the adjustments, let the oscilloscope and test equipment warm up for at least 30 minutes.

Read All Cautions and Warnings

Read the following cautions and warning before making adjustments or performing self-calibration.

WARNING

HAZARDOUS VOLTAGES!

Read the safety notice at the back of this book before proceeding. Maintenance is performed with power supplied to the oscilloscope and with the protective covers removed. Only trained service personnel who are aware of the hazards involved should perform the maintenance. Whenever possible, perform the procedures with the power cord removed from the oscilloscope.

CAUTION

REMOVE POWER TO AVOID DAMAGE!

Do not disconnect any cables or remove any assemblies with power applied to the oscilloscope. Otherwise, damage to the oscilloscope can occur.



CAUTION

USE EXTERNAL FAN TO REDUCE TEMPERATURE!

When you must operate the oscilloscope with its cover and main shield removed, use an external fan to provide continuous air flow over the samplers (the ICs with heat sinks on them). Air flow over the samplers is reduced when the cover and main shield is removed, which leads to higher than normal operating temperatures. Have the fan blow air across the system board where the heat sinks are located. If the cover is removed but the main shield remains installed and the bottom holes are not blocked, the instrument will cool properly.

CAUTION

AVOID DAMAGE TO ELECTRONIC COMPONENTS!

Electrostatic discharge (ESD) can damage electronic components. When you use any of the procedures in this chapter, use proper ESD precautions. As a minimum, place the oscilloscope on a properly grounded ESD mat and wear a properly grounded ESD strap.

User Calibration

Perform user-calibration:

- Each year or after 2000 hours of operation.
- If the ambient temperature is $>10^{\circ}$ C from the calibration temperature.
- If you want to maximize the measurement accuracy.

The amount of use, environmental conditions, and experience with other instruments help determine if you need shorter User Cal intervals.

User Cal performs an internal self-alignment routine to optimize the signal path in the oscilloscope. The routine uses internally generated signals to optimize circuits that affect channel sensitivity, offset, and trigger parameters. Disconnect all inputs and allow the oscilloscope to warm up before performing this procedure.

Performing User Cal will invalidate your Certificate of Calibration. If NIST (National Institute of Standards and Technology) traceability is required perform the procedures in [Chapter 2](#) in this book using traceable sources.

To perform User Cal

- 1 Set the rear-panel CALIBRATION switch to UNPROTECTED.
- 2 Connect short (12 inch maximum) equal length cables to each analog channel's BNC connector on the front of the oscilloscope. You will need two equal-length cables for a 2-channel oscilloscope or four equal-length cables for a 4-channel oscilloscope.

3 Calibrating and Adjusting

Use 50 Ω RG58AU or equivalent BNC cables when performing User Cal.

- a For a 2-channel oscilloscope, connect a BNC tee to the equal length cables. Then connect a BNC(f)-to-BNC(f) (also called a barrel connector) to the tee as shown below.

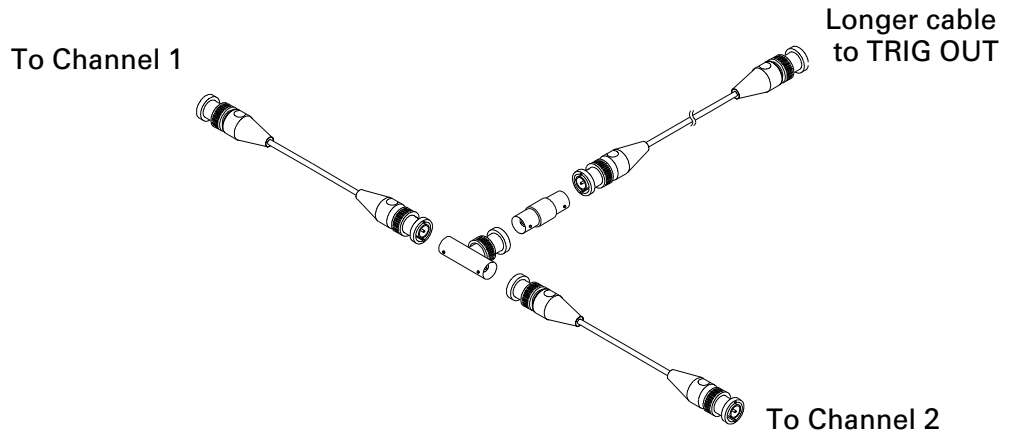

Figure 6 User Calibration cable for 2-channel oscilloscope

- b For a 4-channel oscilloscope, connect BNC tees to the equal-length cables as shown below. Then connect a

BNC(f)-to-BNC(f) (barrel connector) to the tee as shown below.

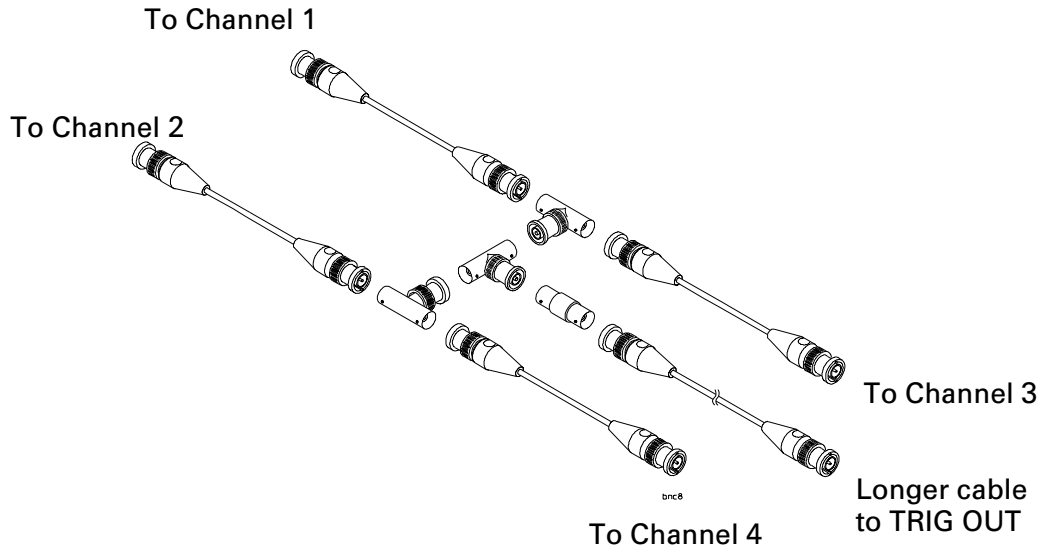

Figure 7 User Calibration cable for 4-channel oscilloscope

- 3** Connect a BNC cable (40 inches maximum) from the TRIG OUT connector on the rear panel to the BNC barrel connector.
- 4** Press the **Utility** key, then press the **Service** softkey.
- 5** Begin the Self Cal by pressing the **Start User Cal** softkey.
- 6** When the User Cal is completed, set the rear-panel CALIBRATION switch to PROTECTED.

User Cal Status

Pressing the **User Cal Status** softkey displays the following summary results of the previous User Cal, and the status of probe calibrations for probes that can be calibrated. Note that AutoProbes do not need to be calibrated, but InfiniiMax can be calibrated.

Results:

User Cal date:

Change in temperature since last User Cal:

Failure:

Comments:

Probe Cal Status:

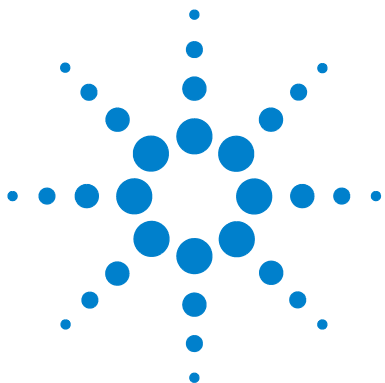

4 Troubleshooting

This chapter begins with suggestions for solving general problems that you may encounter with the oscilloscope. It tells you what to do in these cases:

- If there is no trace display
- If the trace display is unusual or unexpected
- If you cannot see a channel
- If you cannot get any response from the oscilloscope

Procedures for troubleshooting the oscilloscope follow the problem solving suggestions. The troubleshooting section shows you how to:

- Check out the oscilloscope
- Use the troubleshooting flowcharts
- Check power supply
- Check the system board
- Check the display
- Check the fan
- Run internal self-tests
- Verify default setup

Read All Cautions and Warnings

Before you begin any troubleshooting, read all Warning and Cautions in the “Troubleshooting” section



Solving General Problems with the Oscilloscope

This section describes how to solve general problems that you may encounter while using the Agilent 6000 Series Oscilloscopes to make measurements.

After troubleshooting the oscilloscope, if you need to replace parts, refer to the “Replaceable Parts” chapter.

If there is no display

- ✓ Check that the power cord is connected to the oscilloscope and to a live power source.
- ✓ Check that the front-panel power switch is on.
- ✓ Check that the display is illuminated and that the INTENSITY knob is adjusted correctly.
- ✓ If there is still no display, go to the troubleshooting procedures in this chapter.

If there is no trace display

- ✓ Recal the default setup by pressing **Save/Recall** then **Default Setup**. This will ensure that the Trig Mode is Auto.
- ✓ Check that the oscilloscope probe lead wires are securely inserted into the connector assembly and that the probe clips make good contact with the probe lead wires.
- ✓ Check that the probe clips are securely connected to points in the circuit under test, and that the ground is connected.
- ✓ Check that the circuit under test is powered on.
- ✓ Press the **Autoscale** key.
- ✓ Obtain service from Agilent Technologies, if necessary.

If the trace display is unusual or unexpected

- ✓ Check that the Horizontal time/division setting is correct for the expected frequency range of the input signals.
- ✓ The sampling speed of the oscilloscope depends on the time/division setting. It may be that when time/division is set to slower speeds, the oscilloscope is sampling too slowly to capture all of the transitions on the waveform. Use peak detect mode.
- ✓ Check that all oscilloscope probes are connected to the correct signals in the circuit under test.
- ✓ Check to see that the ground lead on the cable is securely connected to ground in the circuit under test. For high-speed measurements, each probe's individual ground lead should also be connected to a ground point closest to the signal point in the circuit under test.
- ✓ Use chapter 2 for information on probing considerations.
- ✓ Check that the trigger setup is correct.
- ✓ A correct trigger setup is the most important factor in helping you capture the data you desire. See the User's Guide for information about triggering.
- ✓ Check that infinite persistence in the Display menu is turned off, then press the **Clear Display** softkey.
- ✓ Press the **Autoscale** key.

If you cannot see a channel

- ✓ Recal the default setup by pressing **Save/Recall** then **Default Setup**. This will ensure that the Trig Mode is Auto.
- ✓ Check that the oscilloscope probe cable is securely connected to the input connector.
- ✓ Check that the oscilloscope probe lead wires are securely inserted into the connector assembly and that the probe clips make good contact with the probe lead wires.

- ✓ Check that the probe clips are securely connected to points in the circuit under test.
- ✓ Check that the circuit under test is powered on.

You may have pressed the **Autoscale** key before an input signal was available.

Performing the checks listed here ensures that the signals from the circuit under test will be seen by the oscilloscope. Perform the remaining checks in this topic to make sure the oscilloscope channels are on, and to obtain an automatic setup.

- ✓ Check that the desired oscilloscope channels are turned on.
 - a** Press the analog channel key until it is illuminated.
 - b** Press the digital channels (**D15 Thru D0** key) until it is illuminated. Ensure that the desired channels are turned on.
- ✓ Press the **Autoscale** key to automatically set up all channels.

Troubleshooting the Oscilloscope

The service policy for the Agilent 6000 Series Oscilloscopes is assembly level replacement. If you need parts or assistance from Agilent Technologies to repair your instrument, go to www.agilent.com and locate the service facility for your area.

WARNING**HAZARDOUS VOLTAGES EXIST — REMOVE POWER FIRST !**

The maintenance described in this section is performed with power supplied to the oscilloscope and with the protective covers removed. Only trained service personnel who are aware of the hazards involved should perform the maintenance. Whenever possible, perform the procedures with the power cord removed from the oscilloscope. Read the safety notice at the back of this book before proceeding.

CAUTION**REMOVE POWER TO AVOID DAMAGE !**

Do not disconnect any cables or remove any assemblies while power is applied to the oscilloscope, or damage to the oscilloscope can occur.

CAUTION**AVOID ESD DAMAGE TO COMPONENTS !**

ELECTROSTATIC DISCHARGE (ESD) can damage electronic components. Use proper ESD precautions when doing any of the procedures in this chapter. As a minimum, place the oscilloscope on a properly grounded ESD mat and wear a properly grounded ESD strap.

Equipment required for troubleshooting

The equipment listed in this table is required to troubleshoot the oscilloscope.

Table 12 Equipment Required to Troubleshoot the Oscilloscope

Equipment	Critical Specifications	Recommended Model/Part
Digital multimeter	Accuracy $\pm 0.05\%$, 1 mV resolution	Agilent 34401A
Oscilloscope	100 MHz, 1 M Ω input R	Agilent 54642A

To check out the oscilloscope

- 1 Disconnect any external cables from the front panel.
- 2 Disconnect the power cord, then remove the cabinet following the instructions on [page 87](#).

CAUTION

USE AN EXTERNAL FAN TO AVOID OVERHEATING COMPONENTS !

When you remove the oscilloscope cover and main shield, use an external fan to provide continuous air flow over the heat sinks. Air flow over the heat sinks is reduced when the cover and main shield is removed, which leads to higher than normal operating temperatures. Have the fan blow air across the system board where the heat sinks are located. If the cover is removed but the main shield remains installed and the bottom holes are not blocked, the instrument will cool properly. Otherwise, damage to the components can occur.

- 3 Connect the power cord to the rear of the oscilloscope, then to a suitable ac voltage source.

The oscilloscope power supply automatically adjusts for input line voltages in the range of 100 to 240 VAC. Ensure that you have the correct line cord (see [Table 16](#) on page 131). The power cord provided is matched to the country of origin.

WARNING

AVOID INJURY.

Always operate the oscilloscope with an approved three conductor power cable. Do not negate the protective action of the three conductor power cable.

- 4 Press the power switch.
 - When the oscilloscope is turned on, the front panel LEDs will light up in the sequence shown in [Figure 8](#) on page 71.
 - Next the Agilent logo and advisory screen will appear on the LCD before the trace display appears.
 - It will take about 3 to 4 seconds for the instrument to turn on. The instrument will go through the basic self test to make sure all the major hardware is working correctly.

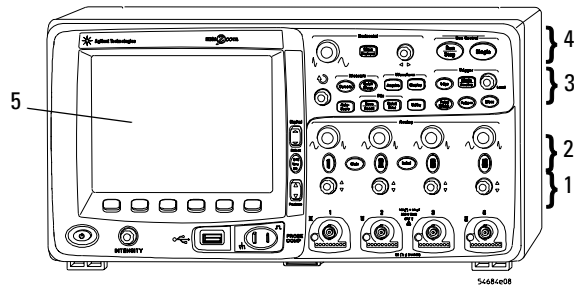

Figure 8 Start up sequence

- 5 If the oscilloscope does not turn on as described, use the troubleshooting flowcharts in this chapter to isolate the problem.

To verify basic oscilloscope operation

- 1 Press the **Save/Recall** key on the front panel, then press the **Default Setup** softkey under the display. The oscilloscope is now configured to its default settings.
- 2 Connect an oscilloscope probe from channel 1 to the **Probe Comp** signal terminal on the front panel.
- 3 Connect the probe's ground lead to the ground terminal that is next to the **Probe Comp** terminal.
- 4 Press **Autoscale**.

- 5 You should see a waveform on the oscilloscope's display similar to this:

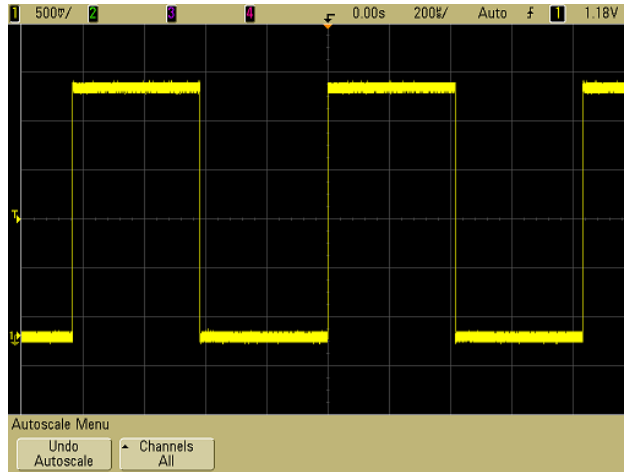

If you see the waveform, but the square wave is not shaped correctly as shown above, perform the procedure [“To compensate the analog probes”](#) on page 73.

If you do not see the waveform, ensure your power source is adequate, the oscilloscope is properly powered-on, and the probe is connected securely to the front-panel analog channel input BNC and to the Probe Comp terminal.

- 6 If you still do not see the waveform, use the troubleshooting flowcharts in this chapter to isolate the problem.

To compensate the analog probes

You should compensate your analog probes to match their characteristics to the oscilloscope's channels. A poorly compensated probe can introduce measurement errors.

- 1 Perform the procedure “[To verify basic oscilloscope operation](#)” on page 71
- 2 Use a nonmetallic tool to adjust the trimmer capacitor on the probe for the flattest pulse possible. The trimmer capacitor is located on the probe BNC connector.

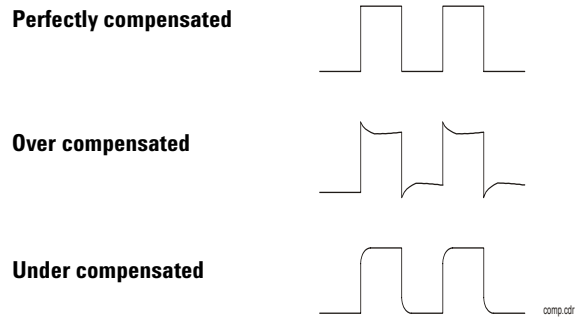

Figure 9 Example pulses

- 3 Connect probes to all other analog channels (channel 2 of a 2-channel oscilloscope, or channels 2, 3, and 4 of a 4-channel oscilloscope). Repeat the procedure for each channel. This matches each probe to each channel.

The process of compensating the probes serves as a basic test to verify that the oscilloscope is functional.

To use the troubleshooting flowcharts

Flowcharts are the primary tool used to isolate defective assemblies. During the troubleshooting instructions, the flowcharts will direct you to perform other tests. The other tests

are located in this chapter after the flow charts. The circled references on the charts indicate connections with other flowcharts or other parts within the same flowchart.

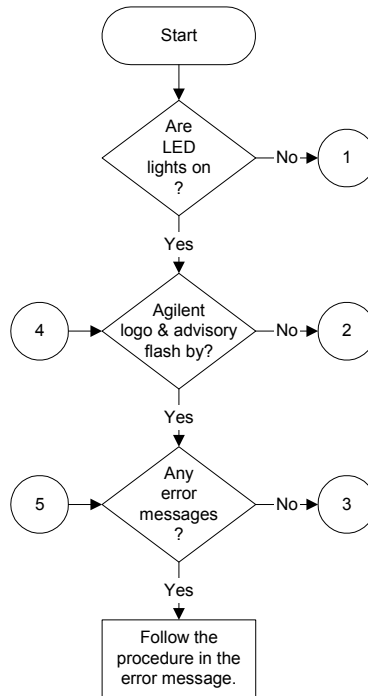

Figure 10 Troubleshooting main flow

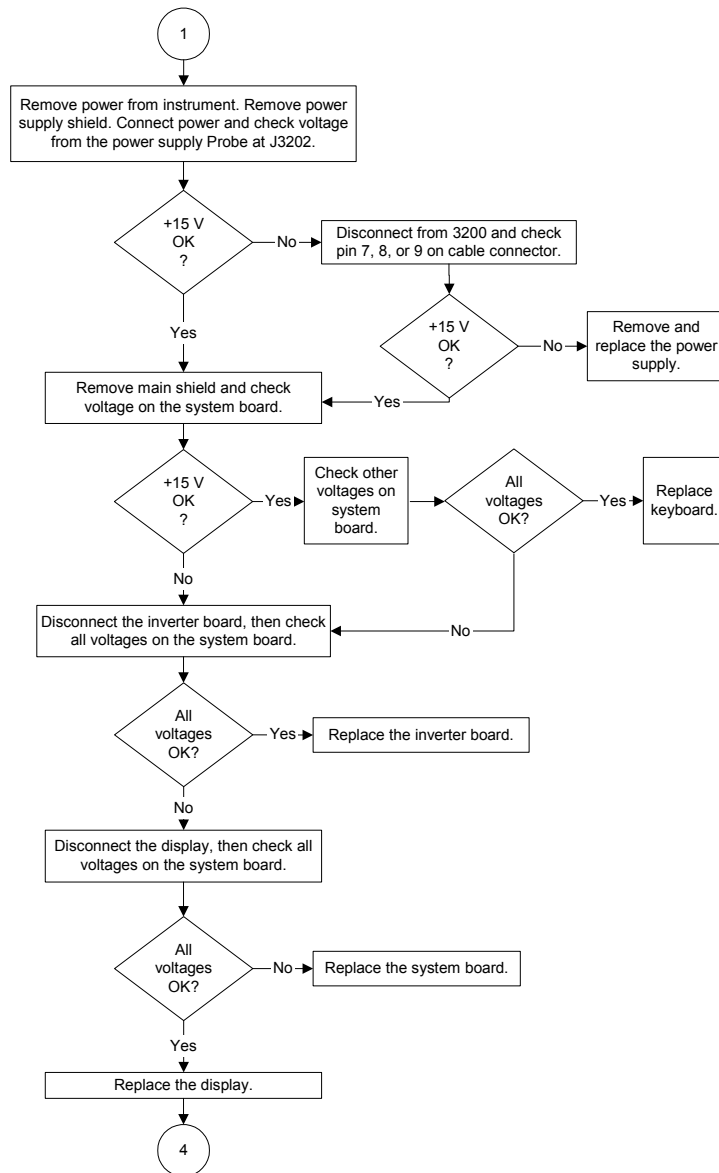

Figure 11 Troubleshooting power (see also “To check the power supply” on page 78)

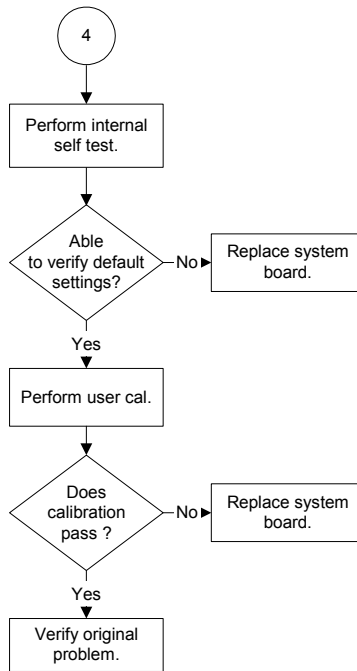

Figure 12 Troubleshooting the system board (see also [“To check the system board”](#) on page 80)

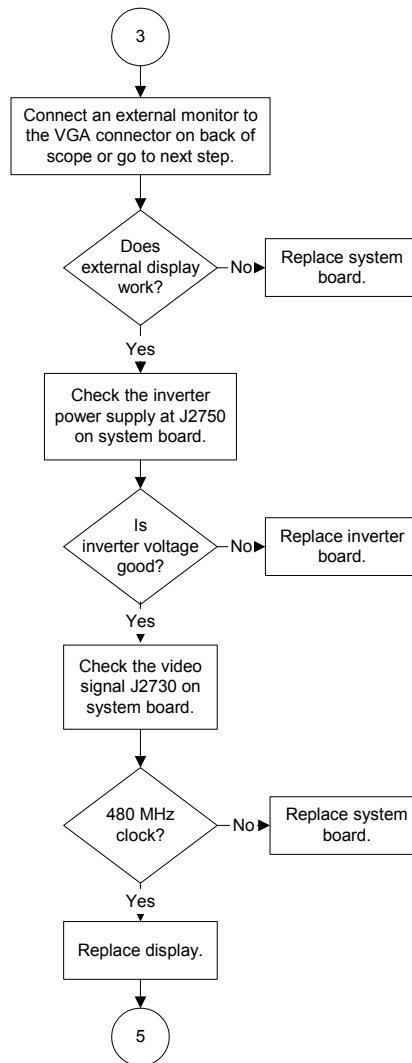

Figure 13 Troubleshooting the display (see also “To check the display” on page 81)

To check the power supply

- 1 Disconnect the power cord from the oscilloscope. Then remove the oscilloscope cabinet and set the oscilloscope on its side.

CAUTION

USE AN EXTERNAL FAN TO AVOID OVERHEATING COMPONENTS !

When you remove the oscilloscope cover and main shield, use an external fan to provide continuous air flow over the heat sinks. Air flow over the heat sinks is reduced when the cover and main shield is removed, which leads to higher than normal operating temperatures. Have the fan blow air across the system board where the heat sinks are located. If the cover is removed but the main shield remains installed and the bottom holes are not blocked, the instrument will cool properly. Otherwise, damage to the components can occur.

- 2 Connect the negative lead of the multimeter to a ground point on the oscilloscope. Connect the power cord and turn on the oscilloscope.
- 3 Measure the power supply voltage at E3202 on the system board. Shown in [Figure 14](#) on page 79.

If the Fuse is Blown

If the power supply fuse is blown, the power supply is defective, and you must replace it. See the “Replaceable Parts” chapter for information about removing the power supply.

WARNING

BEWARE OF HAZARDOUS VOLTAGES !

Be careful when performing component-level repair. Voltages up to 240 VAC exist, and can cause injury.

- 7 Verify other voltage points on the system board.
 - a Refer to [Figure 14](#) on page 79 to locate the points.
 - b Probe at the points in the following table.

Table 13 Other voltage probe points

Probe point	Voltage	From
L3204	3.3 (+- 0.1)	U3202
L3201	5.0 (+- 0.1)	U3202
L3301	1.5 (+- 0.1)	U3300
L3302	-5.2 (+- 0.1)	U3301

- 8 If at any point the voltage appears out of specs then the system board needs to be replaced.

To check the system board

- 1 Remove the cabinet.
- 2 Check that all cable connections are securely connected from the system board to to:
 - Power supply
 - Keyboard
 - Display
 - Inverter board
 - Fan

- 3 If all cables are properly connected and none of the previous tests confirm a failure on another assembly, replace the system board.

To check the display

- 1 Disconnect the power cord.
- 2 Check to verify that the backlight inverter cable is connected.
- 3 Ensure the display LCD cable is connected.
- 4 Use the DVM to check the voltage on the system board (see table below).
- 5 If the voltage is incorrect or absent, replace the system board.
- 6 If the voltage in step 5 is correct, use an Agilent 54642AD oscilloscope to check the LCD clock (see table below).

Table 14 Display Signals on the System Board – All Oscilloscopes

	Signal	Normal/Typical Result
Inverter Power	J2750 Pin 3 or 4	1.45 to 1.95 V
Video Signal	J2730 Pin 6 and 7	480 MHz clock

- 7 If the clock signal is good, replace the LCD.
- 8 If the clock signal is absent, check the power supply voltages on the system board.
- 9 If the voltages are incorrect, replace the system board.

To check the fan

The fan speed is controlled by a circuit on the system board.

- 1 If the fan is running, perform the internal self-tests. Go to [“To run the internal self-tests”](#) on page 83.
- 2 If the fan is not running, it may be defective. Follow these steps:
 - a Disconnect the fan cable from the system board.
 - b Measure the fan voltage at the connector on the system board.

See [Figure 15](#) on page 82 for the location of the fan connector.

- c If the fan voltage is approximately +8.5 Vdc at room temperature, replace the fan. If the fan voltage is not approximately +8.5 Vdc, replace the system board.

The proper voltage range depending on temperature is between +6.0 Vdc to +11.5 Vdc.

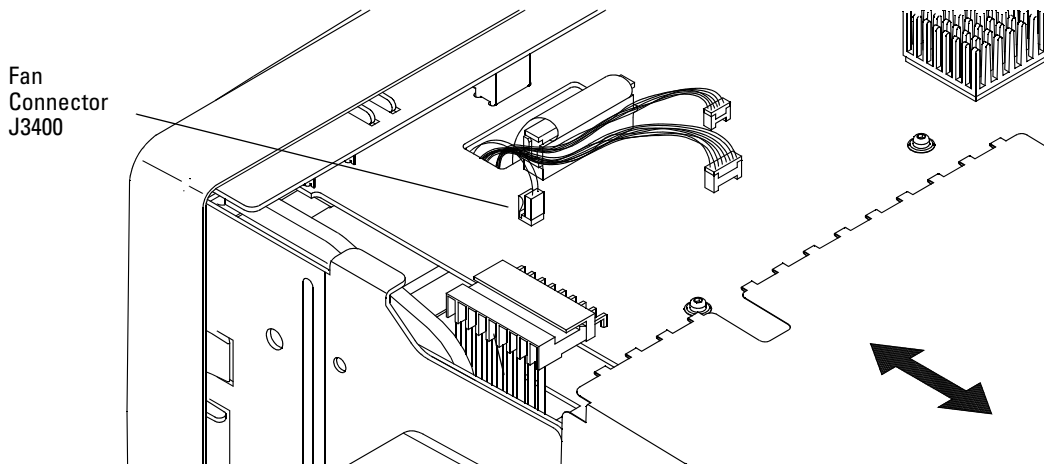

Figure 15 Location of the Fan Connector

To run the internal self-tests

Self Test performs a series of internal procedures to verify that the oscilloscope is operating properly.

It is recommended that you run the Self Test:

- after experiencing abnormal operation
- for additional information to better describe an oscilloscope failure
- to verify proper operation after the oscilloscope has been repaired

Successfully passing Self Test does not guarantee 100% of the oscilloscope's functionality. Self Test is designed to provide an 80% confidence level that the oscilloscope is operating properly.

- 1 Press the **Utility** key, then press the **Service** softkey.
- 2 Begin the internal self tests by pressing the **Start Self Test** softkey.

To verify default setup

The oscilloscope is designed to turn on with the setup from the last turn on or previous setup. To recall the factory default setup:

- 1 Press the **Save/Recall** key.
- 2 Press the **Default Setup** softkey.

This returns the oscilloscope to its factory default settings and places the oscilloscope in a known operating condition. The major default settings are:

- **Horizontal** - main mode, 100 us/div scale, 0 s delay, center time reference
- **Vertical** - Channel 1 on, 5 V/div scale, dc coupling, 0 V position, probe factor to 1.0 if an AutoProbe probe is not connected to the channel
- **Trigger** - Edge trigger, Auto sweep mode, 0 V level, channel 1 source, dc coupling, rising edge slope, 60 ns holdoff time

4 Troubleshooting

- **Display** - Vectors on, 20% grid intensity, infinite persistence off
- **Other** - Acquire mode normal, Run/Stop to Run, cursor measurements off

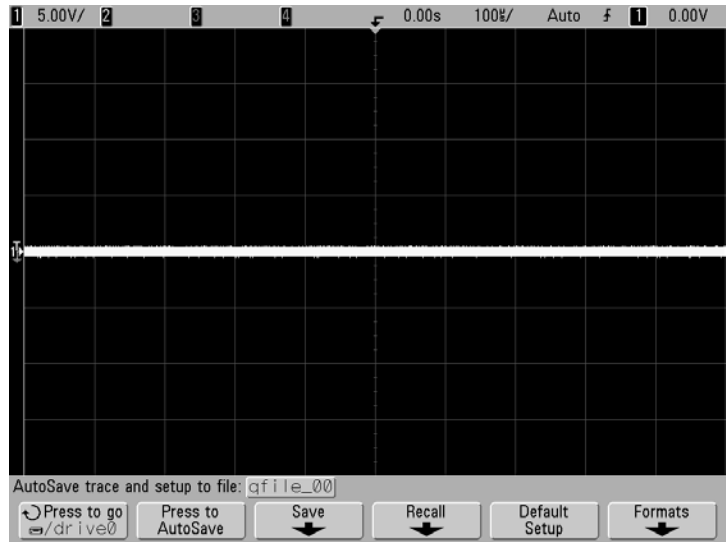

Figure 16 Default setup screen

- 3 If your screen looks different, replace the system board.



5 Replacing Assemblies

This chapter describes how to remove assemblies from the oscilloscope. After you have removed an assembly, to install the replacement assembly, follow the instructions in reverse order.

The parts shown in the following figures are representative and may look different than what you have in your oscilloscope.

The removable assemblies include:

- Cabinet ([page 87](#))
- Handle ([page 88](#))
- Storage Lid ([page 89](#))
- Front Panel ([page 90](#))
- Keyboard ([page 93](#))
- Display Assembly ([page 96](#))
- Backlight Inverter Board and Shield ([page 100](#))
- Liquid Crystal Display ([page 104](#))
- Power Supply Shield ([page 107](#))
- Power Switch ([page 111](#))
- Power Supply ([page 112](#))
- AC Input Board ([page 113](#))
- Fan ([page 114](#))
- System Board ([page 116](#))

Tools Used for Disassembly

Use these tools to remove and replace the oscilloscope assemblies:

- T6, T10, and T20 TORX drivers
- 5/8-inch and 9/32-inch socket drivers



See how the Oscilloscope Parts Fit Together

An exploded view of the oscilloscope is included in the “Replaceable Parts” chapter. It shows the individual part numbers used in the assemblies, and shows you how the parts fit together.

Read All Warnings and Cautions

Read the following warnings and cautions before removing and replacing any assemblies in the oscilloscope.

WARNING

HAZARDOUS VOLTAGES!

Read the safety summary at the back of this book before proceeding. Maintenance is performed with power supplied to the oscilloscope and with the protective covers removed. Only trained service personnel who are aware of the hazards involved should perform the maintenance. Whenever possible, perform the procedures with the power cord removed from the oscilloscope.

WARNING

AVOID ELECTRICAL SHOCK !

Hazardous voltages exist on the LCD assembly and power supply. To avoid electrical shock:

- 1 Disconnect the power cord from the oscilloscope.
- 2 Wait at least three minutes for the capacitors in the oscilloscope to discharge before you begin disassembly.

Read the Safety Summary at the back of this manual before you begin.

CAUTION

REMOVE POWER TO AVOID DAMAGE !

Remove power before you begin to remove and replace assemblies. Do not remove or replace assemblies while the oscilloscope is turned on, or damage to the components can occur.

CAUTION

AVOID DAMAGE TO ELECTRONIC COMPONENTS !

ELECTROSTATIC DISCHARGE (ESD) can damage electronic components. When doing any of the procedures in this chapter, use proper ESD precautions. As a minimum, you should place the instrument on a properly grounded ESD mat and wear a properly grounded ESD strap.

To remove the cabinet

- 1 Turn off the oscilloscope and disconnect the power cable.
- 2 Using the T20 TORX driver, remove the two screws from the rear of the cabinet.
- 3 Using your thumbs, gently push on the rear-panel connectors to slide the oscilloscope out of the cabinet.

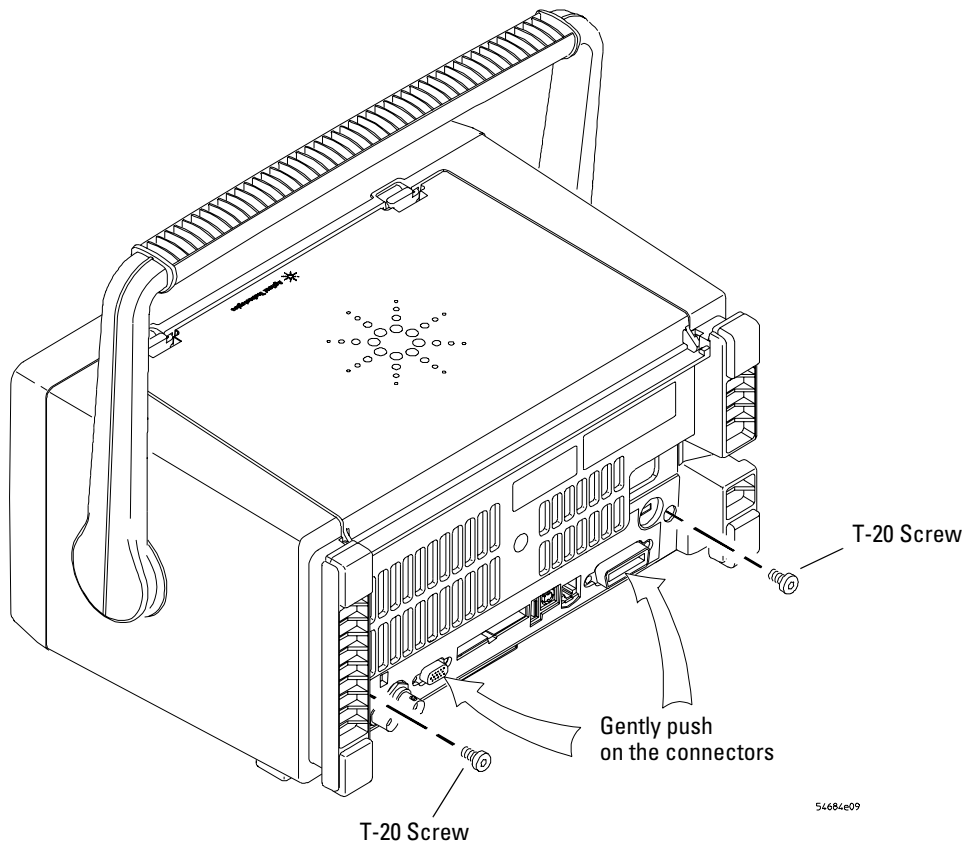

Figure 17 Removing the cabinet

To remove the handle

If you are mounting the instrument on a rack, you will probably need to remove the handle.

- 1 Rotate the handle downward until it just passes the last detent position; this is about 1/2 inch before the handle touches the bottom of the oscilloscope.
- 2 Pull the sides of the handle out of the cabinet and remove.

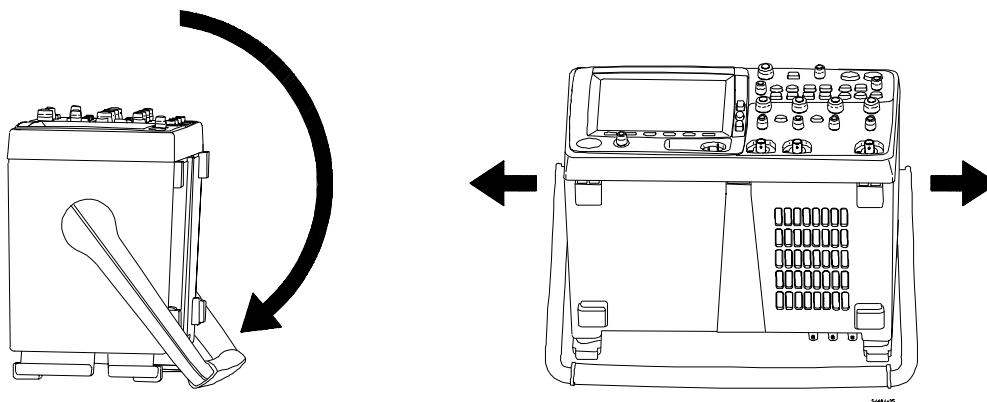

Figure 18 Removing handle

To remove the storage lid

The storage lid is designed to come off without breaking.

- 1 Push back on the lid until it snaps out of the slots.
- 2 To reinstall the lid:
 - a Insert the left hinge into the slot.
 - b Push the lid all the way to the left.
 - c Snap the right hinge into the slot.

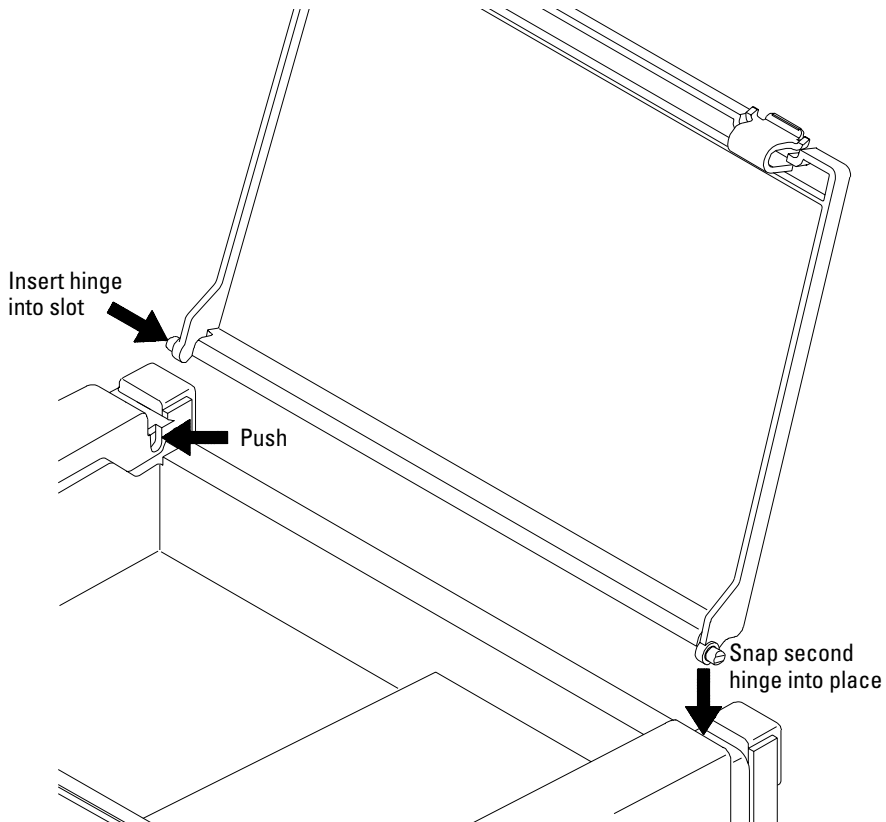

Figure 19 Installing the hinged storage lid

To remove the front panel assembly

1 Perform the following procedures:

- “To remove the cabinet” on page 87

2 Insert a flat-blade screwdriver under the center of the intensity knob and gently twist it as you pull the knob off.

Using a twisting motion rather than prying prevents marking or damaging the front panel.

3 Remove the T6 screws securing the BNC assembly to the deck.

This step helps prevent the BNC connectors from binding when removing and reinstalling the front panel.

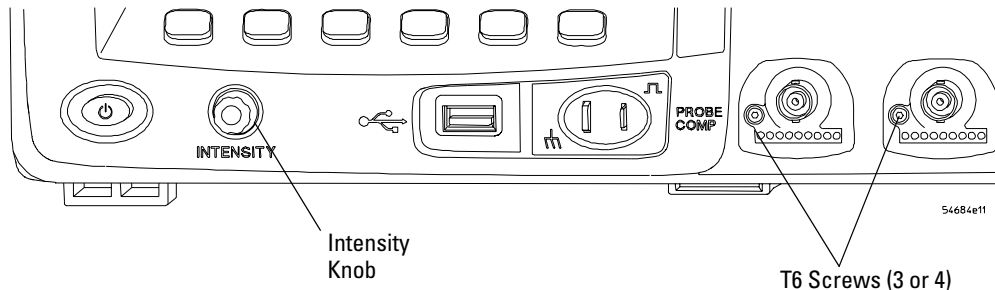

Figure 20 Removing the intensity knob and T6 screws

4 Disconnect the keyboard ribbon cable from the keyboard.

5 Use a flat-blade screwdriver to the release retainer tabs and then push the panel forward.

Ensure that the retainer tab on the display side moves past the rear edge of the display mount.

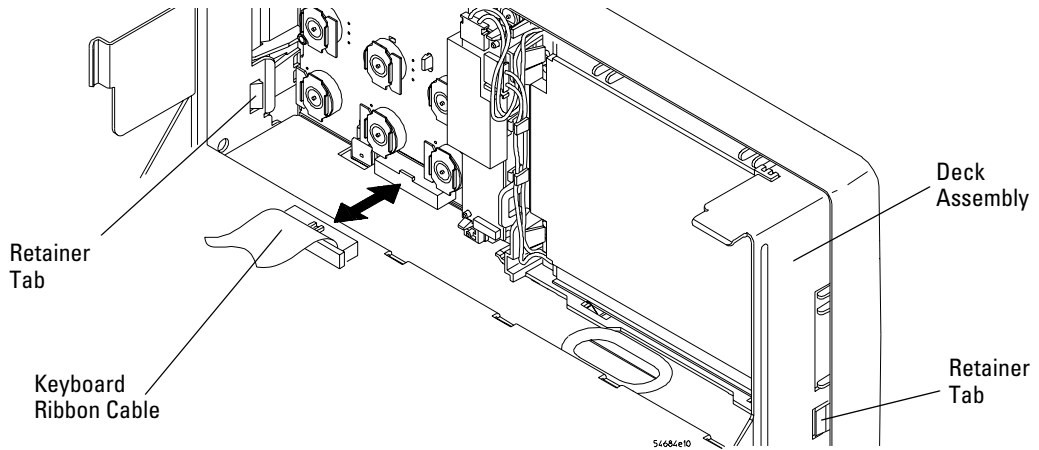

Figure 21 Disconnecting ribbon cable and releasing tab retainers

- 6** Swing the front panel out until the bottom clears the deck assembly, then lift it up to free the hooks on top and pull it away from the deck.

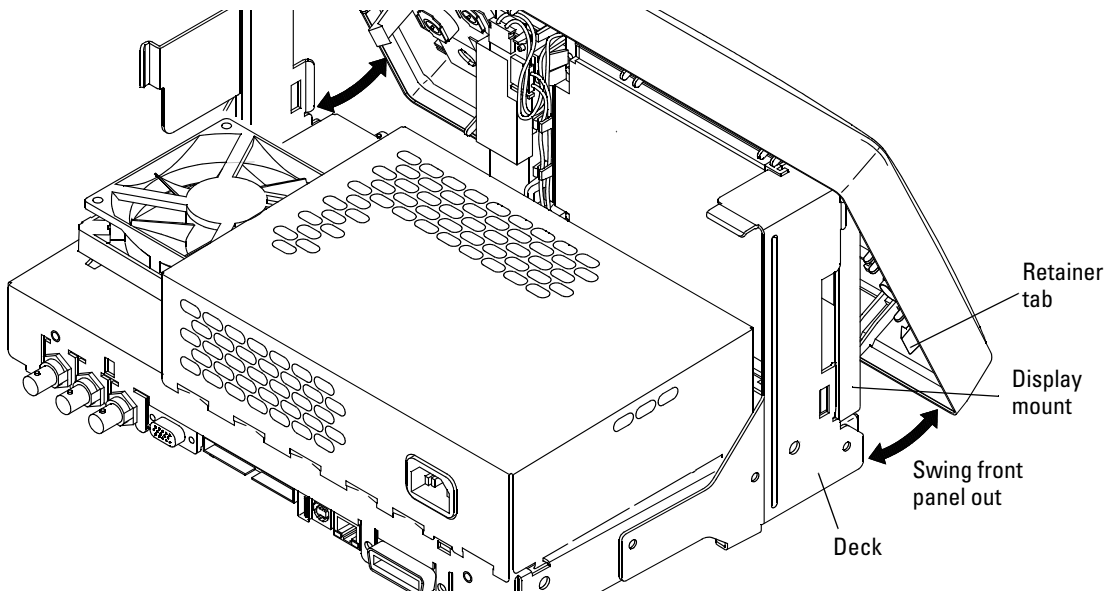

Figure 22 Removing the front panel

- 7** To reinstall the front panel:
 - a** Align the hooks on top of the front panel with their connection holes in the sheet metal and display mount.
 - b** Swing the front panel down and ensure that the power switch, intensity shaft and BNC connectors are aligned with the holes in the front panel.
 - c** Push the front panel until the two retainer tabs click into place in the deck.
 - d** Reinstall the T6 screws on the BNC connectors.
 - e** Connect the keyboard ribbon cable.

To remove the keyboard assembly

- 1 Perform the following procedures:
 - “To remove the cabinet” on page 87
 - “To remove the front panel assembly” on page 90
- 2 If removing the softkey pad only skip steps 3, 4c, and 4d below.
- 3 Remove all of the knobs by pulling them straight out. You may need to use a flat-blade screwdriver to gently pry them as you pull.

Using a twisting motion rather than prying prevents marking or damaging the front panel.

- 4 Remove the main keyboard and softkey board as follows.
 - a Lift the left end of the softkey board enough to clear the tab holding it in place.
 - b Slide the softkey board to the left to release it from the retaining tabs.
 - c Release the 8 latches holding the main keypad board to the front panel.
 - d You will notice the latches do not all face the same direction. This is shown with arrows in the following figure.
 - e Lift the board up just enough to clear the latches.
 - f Lift both boards out being careful not to damage the ribbon cable between them.
- 5 Remove and replace keypads as needed.

5 Replacing Assemblies

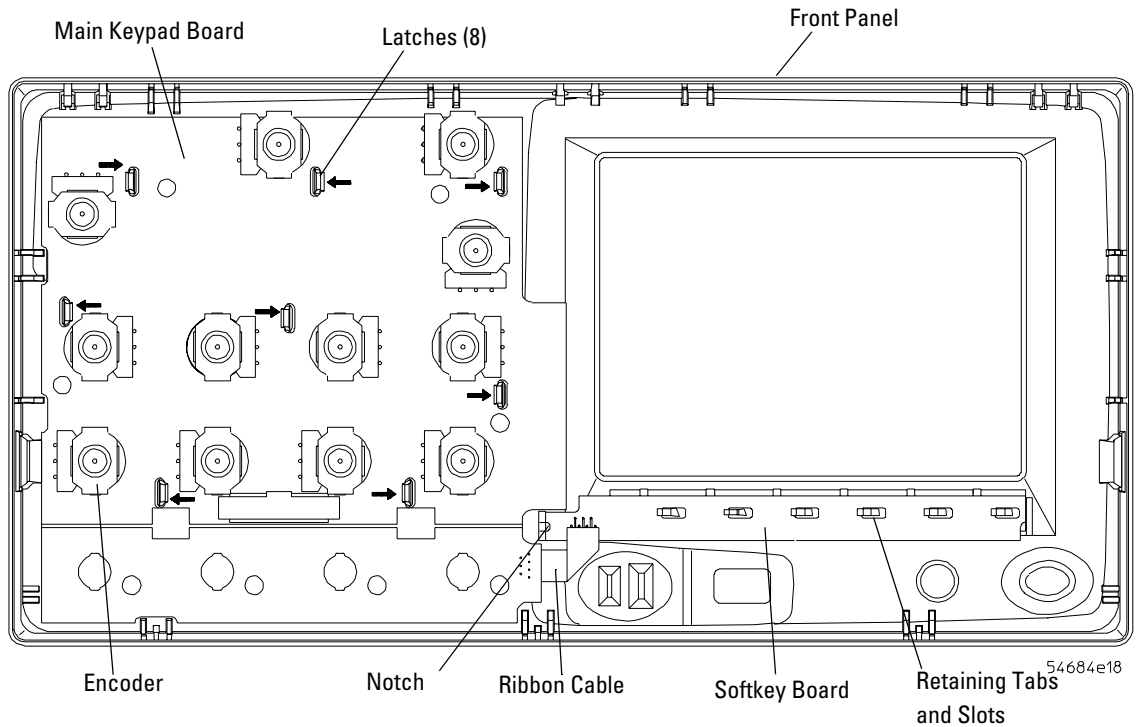

Figure 23 Removing the keyboard assembly

6 When reinstalling the boards:

- a** If you have a new main board assembly, you will need to separate the softkey board from the main keypad board.

Using a needle nose pliers, carefully remove the two process tabs.

Using a needle nose pliers, carefully remove the two break away tabs connecting the two boards.

- b** Carefully turn the softkey board so that the gold metal contacts face the keypad. Note the way the ribbon cable is dressed in the previous figure.
- c** Align the main keypad board over the keypad inserting the knob shafts into their holes.
- d** Snap the main keypad board in place by pressing on the encoders near each latch. Ensure all 8 catch.
- e** Align the slots in the softkey board over the retaining tabs.
- f** Push down on the softkey board. Using a tool (such as a soldering aid) in the notch of the board, slide it to the right until it seats between the tabs.
- g** Replace the knobs by supporting the back of each encoder and pushing the knob fully onto the shaft.

To remove the display assembly

- 1 Perform the previous procedures:
 - “To remove the cabinet” on page 87
 - “To remove the front panel assembly” on page 90
- 2 Remove the main shield covering the system board by sliding it toward the back of the instrument.

WARNING

Thin sheet metal parts may have sharp edges. Handle with care to avoid injury.

- 3 Using a small flat blade screw driver, gently pry the display and backlight inverter cables to disconnect them from the system board.

Note the cable routing through the system board for reinstallation.

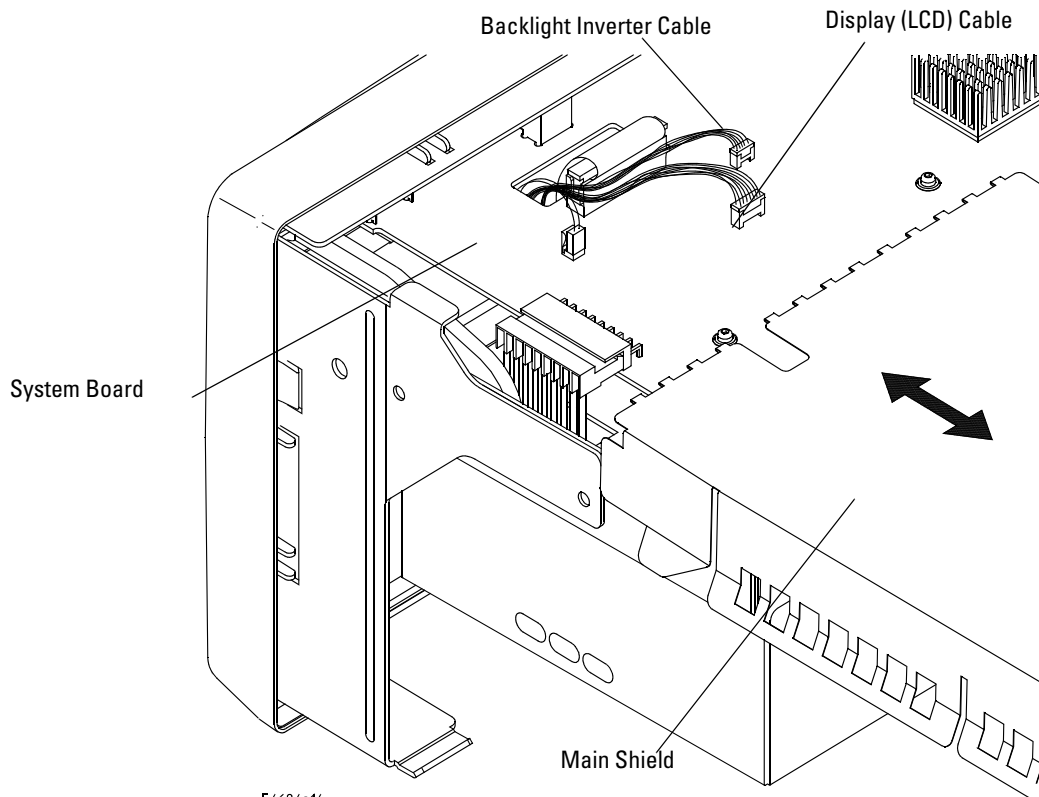

Figure 24 Removing the main shield and disconnecting the display cables

- 4** Using a flat-blade screwdriver, lift the latch tab at the bottom of the display assembly just enough to clear the slot in the deck.
- 5** Push the entire display assembly to the right to release the retaining hooks from their slots in the deck
- 6** Lift and remove the display assembly.

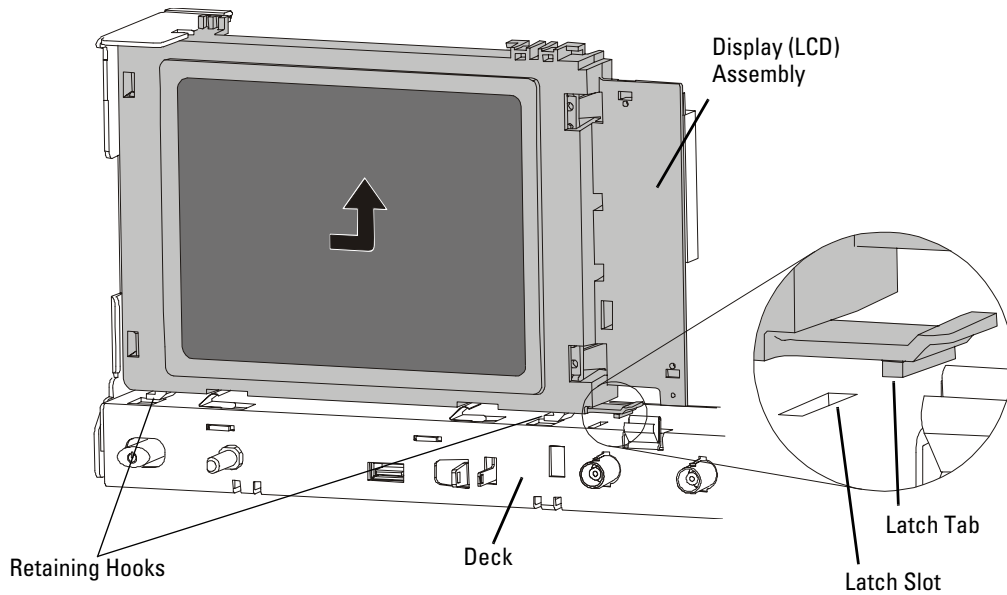

Figure 25 Removing the display assembly

7 To reinstall the display:

- a** Align the top locating tab with the locating slot in the sheet metal and the retaining hooks with their retaining holes.
- b** Push down on the LCD until it is flat with the deck and at the same time push the LCD to your left.
- c** Ensure the latch tab is seated in its hole as shown in [Figure 25](#).
- d** Route the cables down through the deck hole and reconnect to the system board as shown in [Figure 24](#).

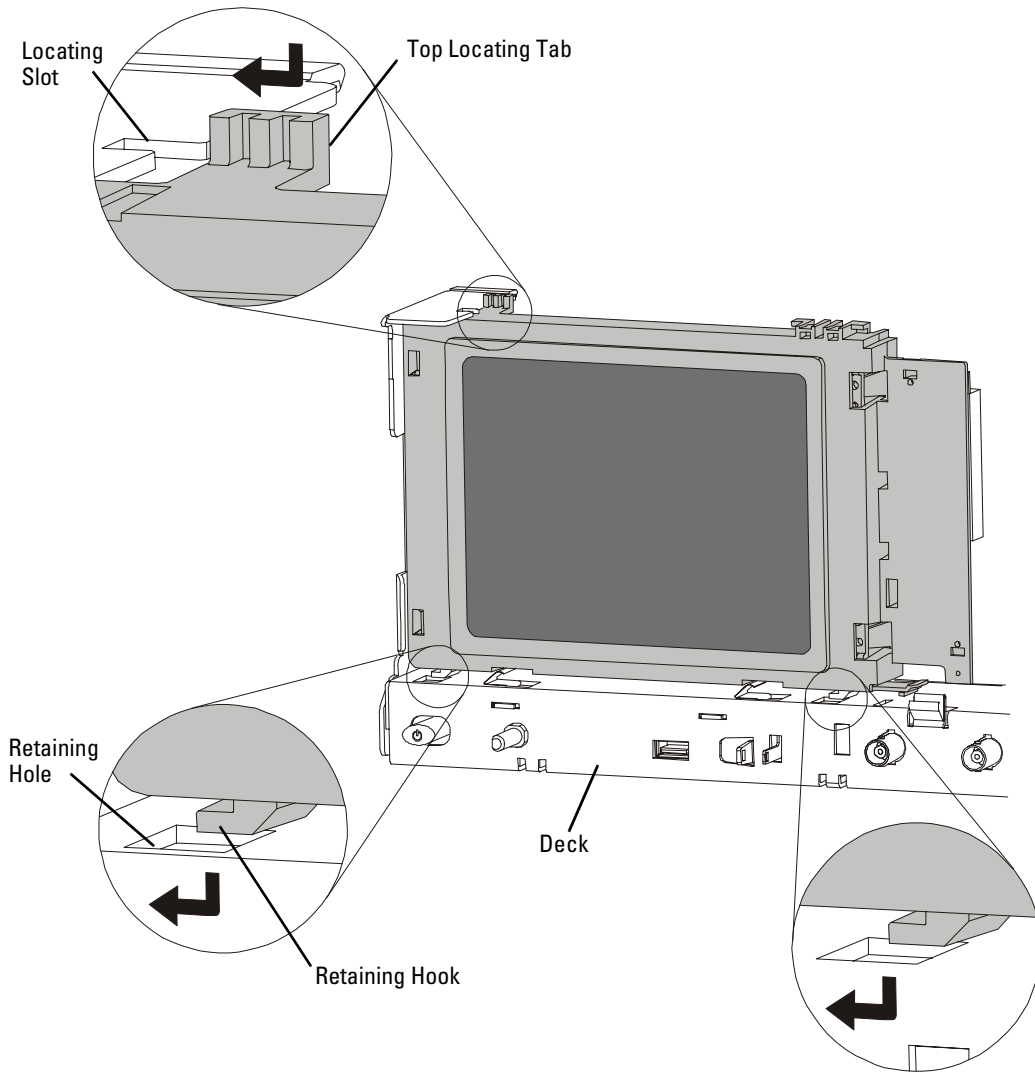
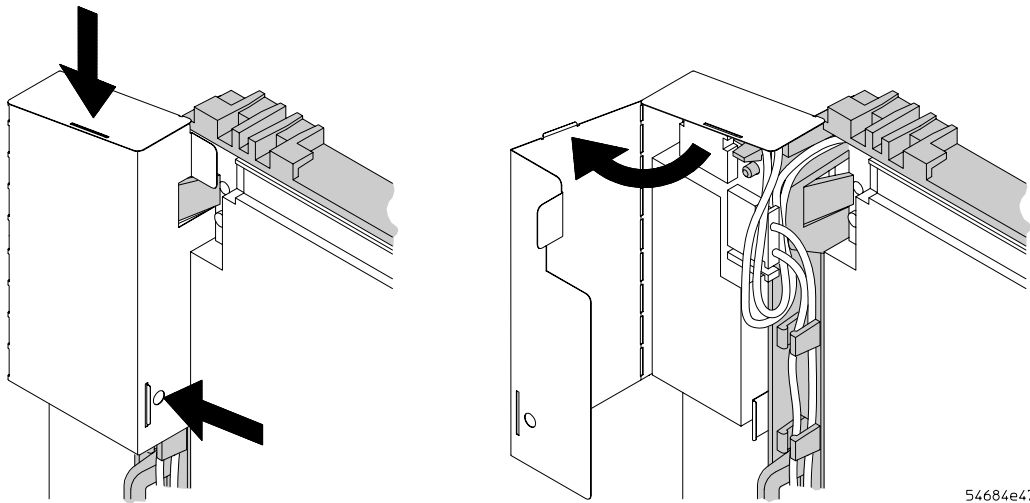

Figure 26 Installing the display

To remove the backlight inverter board and e-field shield

Some older oscilloscope models may not have the e-field shield mentioned in this procedure.

- 1 Perform the previous procedures:
 - “To remove the cabinet” on page 87
 - “To remove the power supply shield” on page 107
- 2 Press to release the top tab and use the hole to aid in releasing the side tab. Then open the shield. Do not bend it past the vertical position as shown.



54684e47

Figure 27 Opening the backlight inverter shield

- 3 Remove the LCD cables from the cable guides.
- 4 Release the top latch and lift the top of the board off the top alignment post.
- 5 Release the bottom latch and lift the board off the bottom alignment post.

- 6 Disconnect the LCD cables from the backlight inverter board.
- 7 Unplug the supply cable from the inverter board.

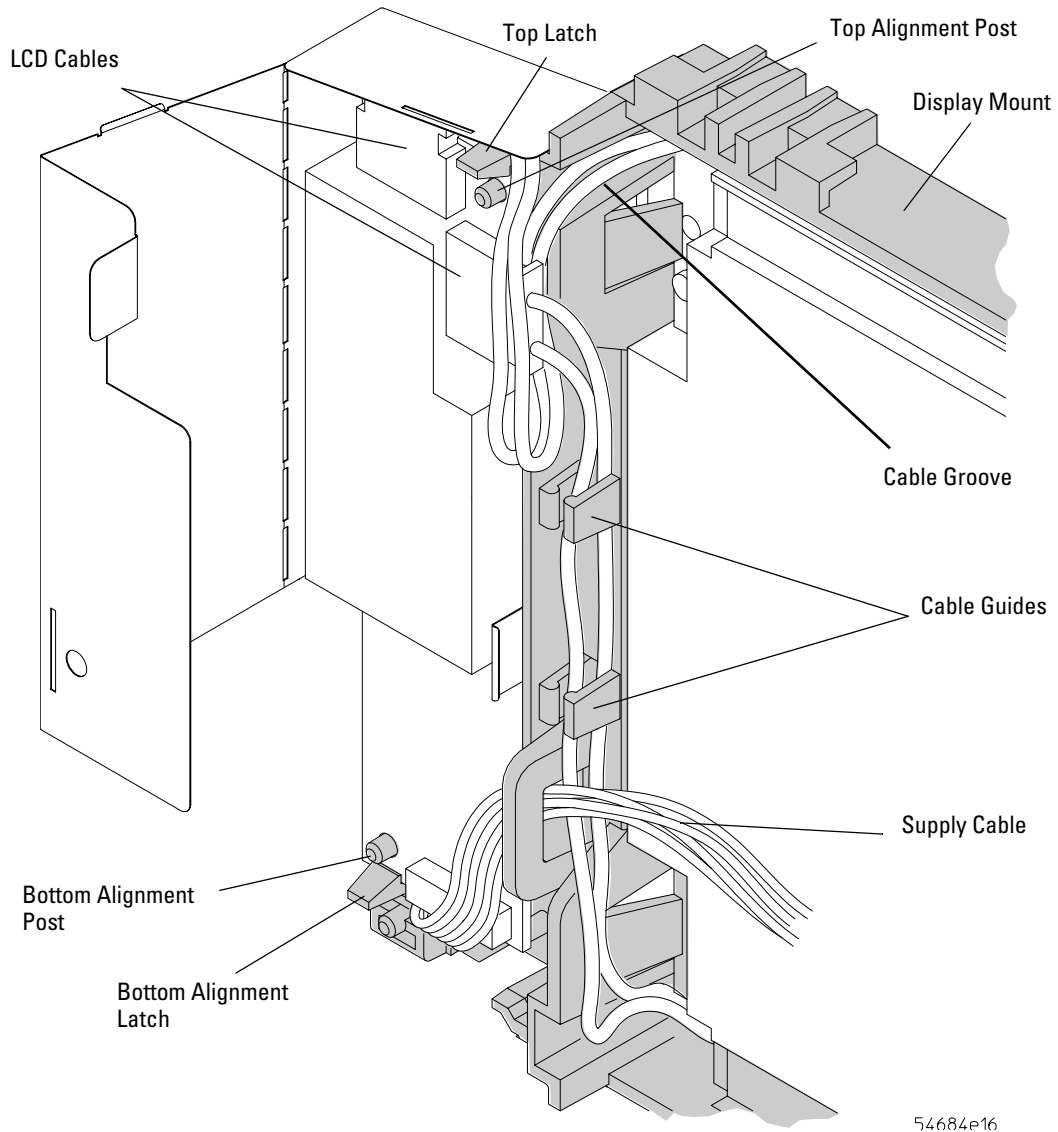

54684e16

Figure 28 Removing the backlight inverter

- 8 If the e-field shield requires replacement, use a screwdriver to pry the shield off the studs.

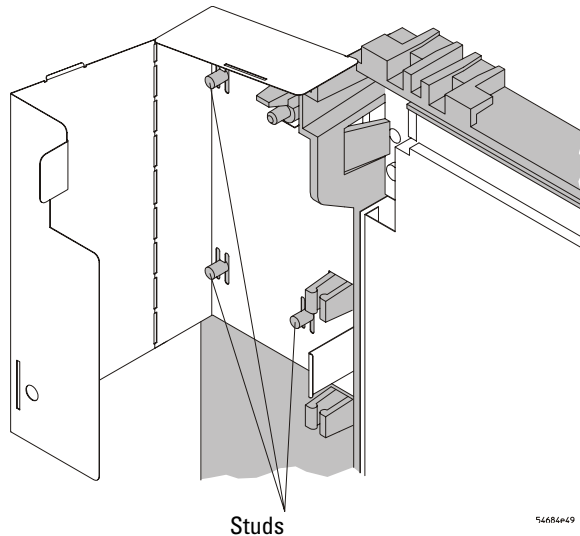
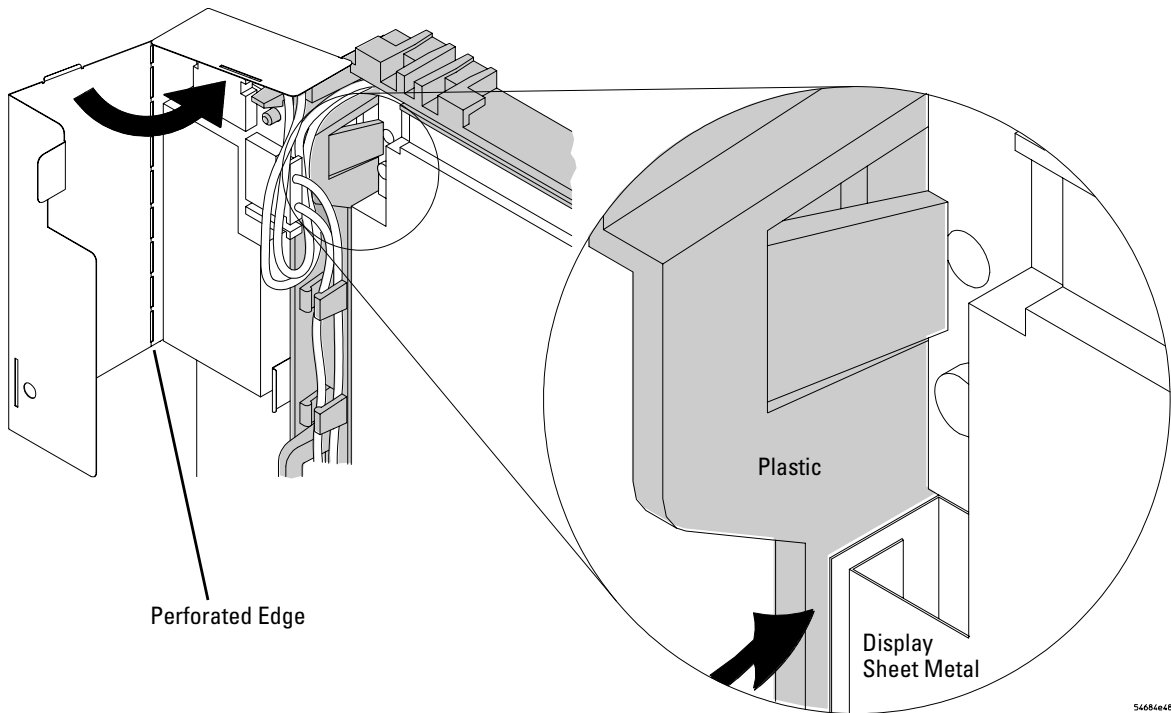

Figure 29 Removing the backlight inverter shield

- 9 To reinstall the backlight inverter board:
- a Align the shield over the studs and push it all the way down on the studs.
 - b Reconnect the LCD cables looping them around each other and through the cable guides as shown in [Figure 28](#).
 - c Reconnect the supply cable.
 - d Align the holes in the inverter board with the posts on the display mount and push down until the latches snap over the board (refer to [Figure 28](#)).
 - e Route the cables through the cable guides as shown.

f Close the shield.

- Insert the shield between the plastic and sheet metal of the display.
- Ensure the cables do not get pinched.
- After closing, use your fingers to gently pinch along the perforated edge of the shield to square the corner and ensure that the release tabs are in their slots.

**Figure 30** Closing the shield

To remove the LCD, gasket, and protective lens from the display mount

- 1 Perform the following procedures:
 - “To remove the cabinet” on page 87
 - “To remove the front panel assembly” on page 90
 - “To remove the display assembly” on page 96
 - “To remove the backlight inverter board and e-field shield” on page 100
- 2 Use a long-nose pliers or flat-blade screwdriver to push and release the two LCD latches on the left side of the display mount.

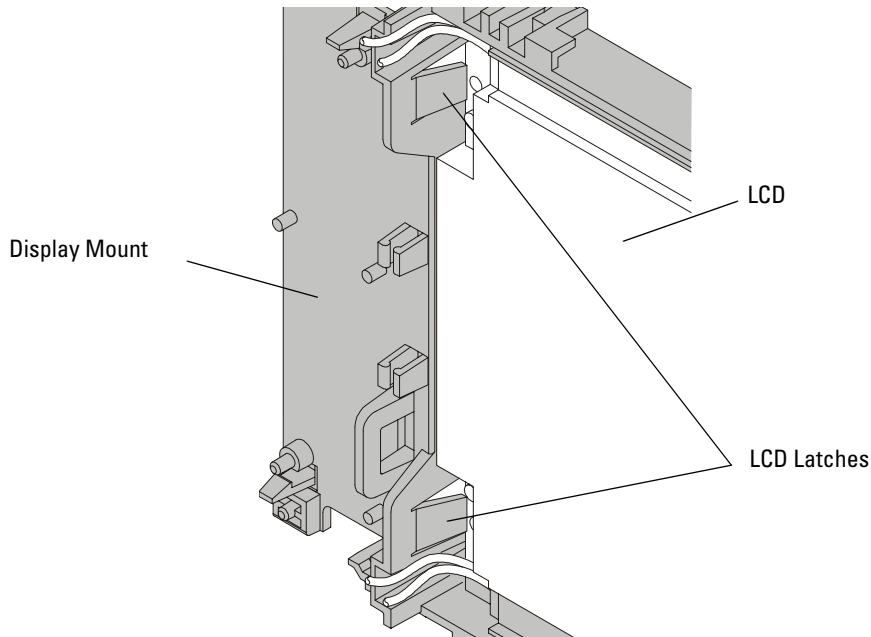

Figure 31 Release display mount latches

- 3 Lift and remove the LCD from under the guides on the right side of the display mount.
 - 4 Remove the gasket and protective lens if necessary.
- Note the orientation of the gasket.

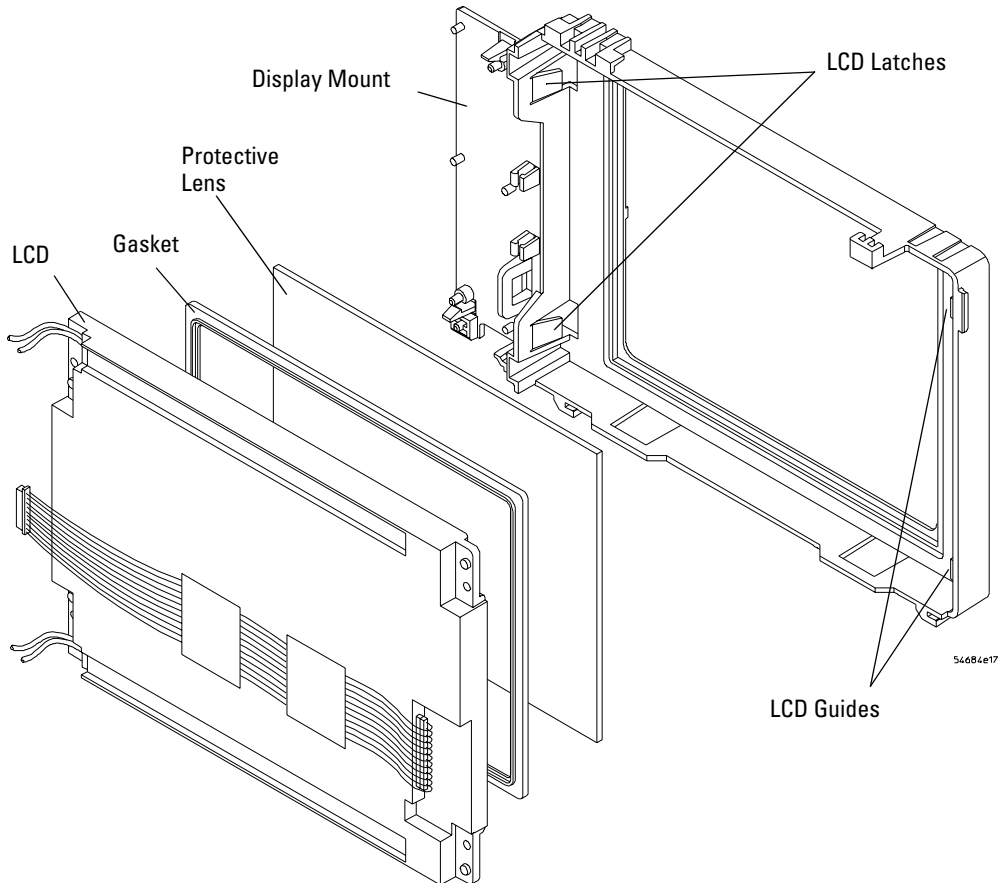

Figure 32 Removing the LCD, gasket, and protective lens

- 5** To reinstall:
- a** Place the protective lens into the pocket in the display mount and ensure that the inside of the lens is clean.
 - b** Place the gasket into the slot around the lens making sure it is fully seated in the slot all the way around.
 - c** Clean the LCD window and insert the LCD under the guides on the right side of the display mount.
 - d** Push the left side of the LCD down until it clicks under the latches so that the latches are fully over the face of the sheet metal housing.

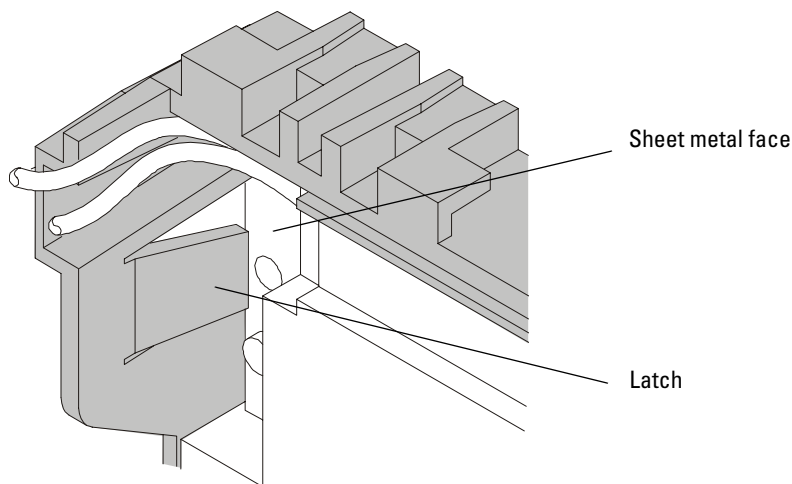

Figure 33 Latch over face of sheetmetal housing

- e** Reinstall the backlight inverter (see [step 9](#) on [page 102](#)).

To remove the power supply shield

- 1 Perform the previous procedures:
“To remove the cabinet” on page 87
- 2 Pull the shield back to release the 4 side hook legs from the deck.

WARNING

Thin sheet metal parts may have sharp edges. Handle with care to avoid injury.

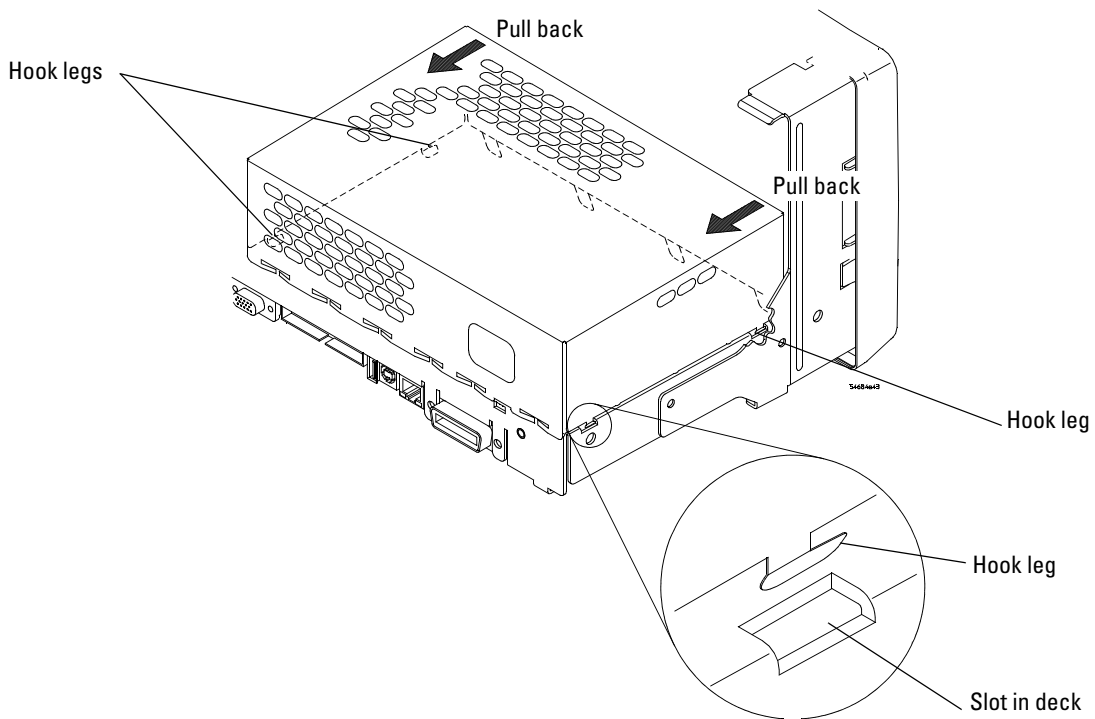

Figure 34 Release hook legs from deck.

5 Replacing Assemblies

- 3 Lift to remove the shield.
- 4 When reinstalling:
 - a Ensure dielectric insulator tape is in place.

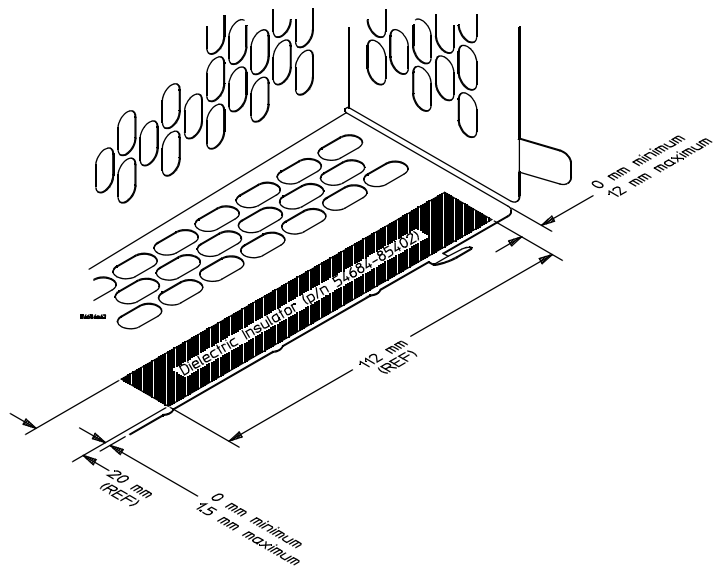
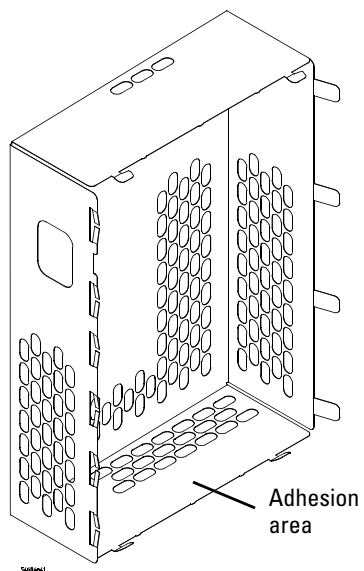

Figure 35 Dielectric insulator tape.

b Ensure that tabs and hook legs have not been damaged.

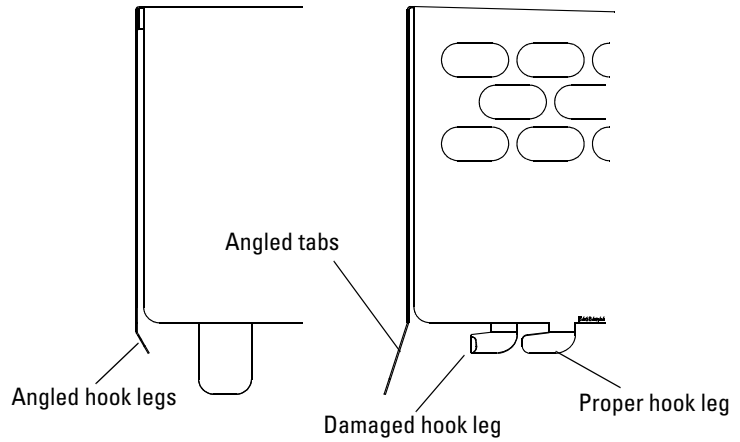

Figure 36 Proper angles for tabs and hook legs.

c Insert the 4 tabs at the front of the shield by tilting the shield up.

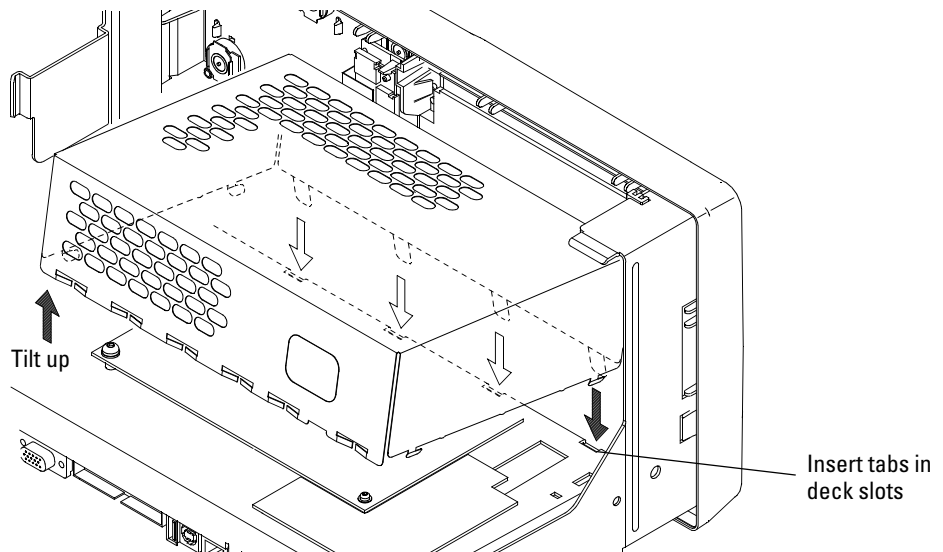

Figure 37 Tilt to insert tabs.

- d Tilt the shield down and pull back slightly to insert the 4 side hook legs into their deck slots.
- e Push the shield forward to lock into place.

Ensure all hooks and tabs are correctly in their holes.

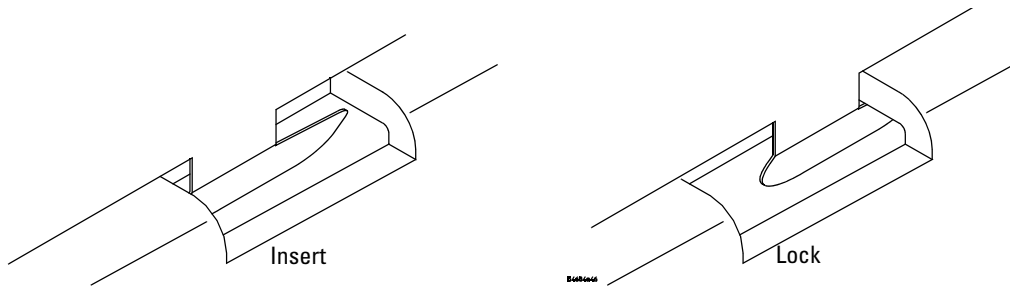

Figure 38 Insert hook legs and lock in place.

To remove the power supply

- 1 Perform the previous procedures:
 - “To remove the cabinet” on page 87
 - “To remove the power supply shield” on page 107
- 2 Disconnect the power supply and AC cables.
- 3 Remove the 4 T10 screws securing the power supply to the deck, then remove the power supply.

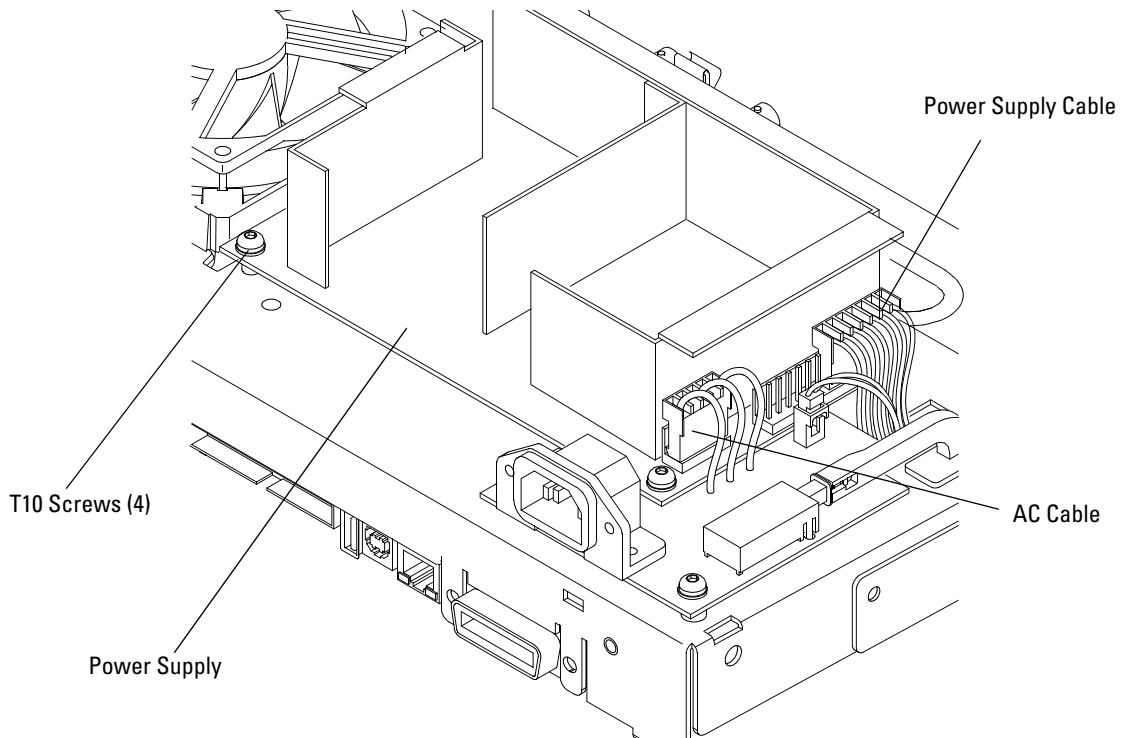

Figure 39 Removing the power supply

- 4 Reverse this procedure to install the power supply.

To remove the power shaft

- 1 Perform the previous procedures:
 - “To remove the cabinet” on page 87
 - “To remove the power supply shield” on page 107
- 2 Use a flat-blade screwdriver to gently spread the latch while pushing the power shaft forward.

CAUTION

Twisting the latch too much could cause it to break!

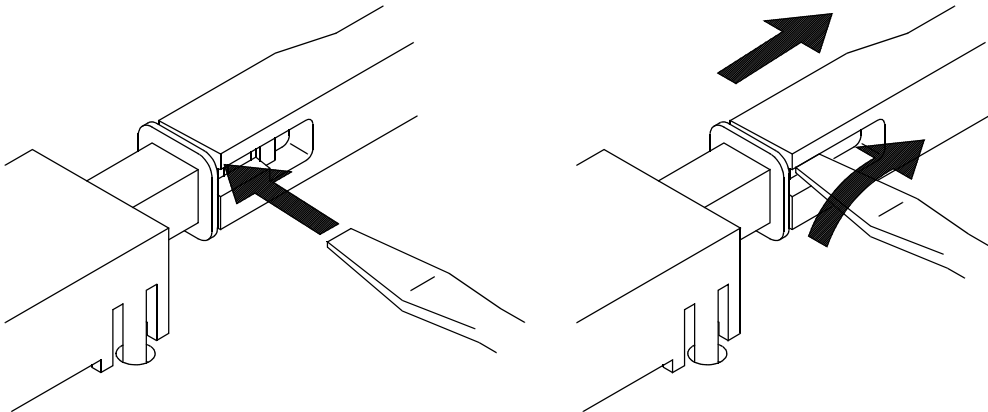

54684a28

Figure 40 Removing the power shaft latch

- 3 Lift and remove it from the deck.
- 4 When reinserting the power shaft, push the shaft into the power switch until the shaft snaps onto the switch.

To remove the AC input board

- 1 Perform the previous procedures:
 - “To remove the cabinet” on page 87
 - “To remove the power supply shield” on page 107
 - “To remove the power shaft” on page 112
- 2 Disconnect the black power supply cable and the AC input cable.
- 3 Remove the T15 screw securing the input board to the deck.
- 4 Slide the board to the right to release it from the 2 posts.
- 5 Remove the board.

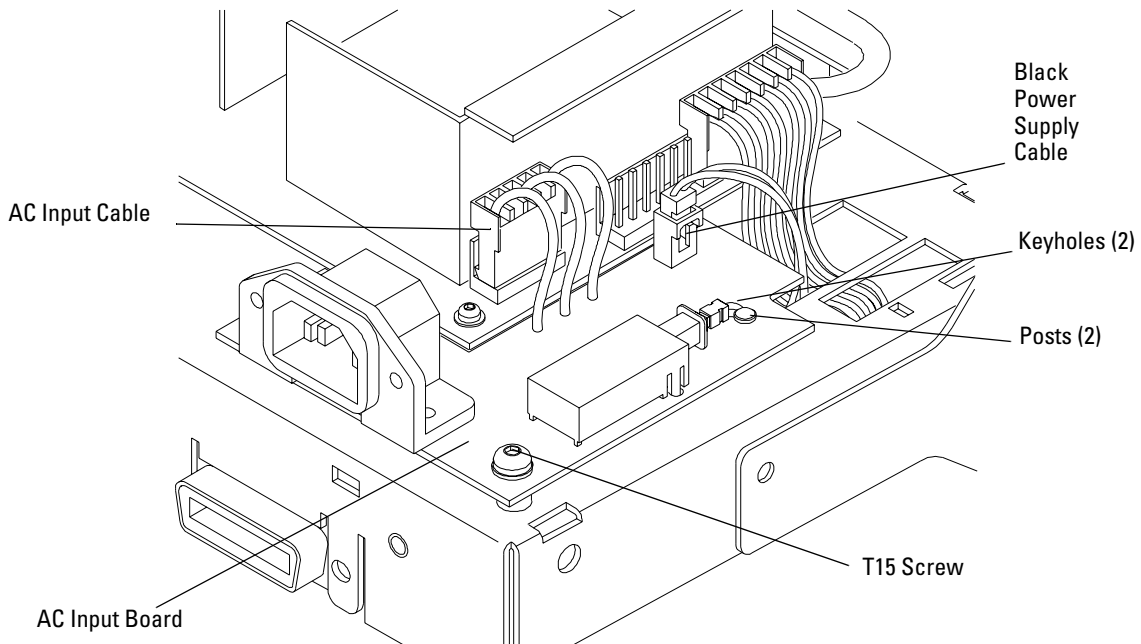

Figure 41 Removing the AC input board

- 6 Reverse this procedure to reinstall.

To remove the fan

- 1 Perform the previous procedures:
 - “To remove the cabinet” on page 87
 - “To remove the power supply shield” on page 107
 - “To remove the power supply” on page 111
- 2 Remove the main shield covering the system board by sliding it toward the back of the instrument.

WARNING

Thin sheet metal parts may have sharp edges. Handle with care to avoid injury.

- 3 Disconnect the fan cable from the system board.

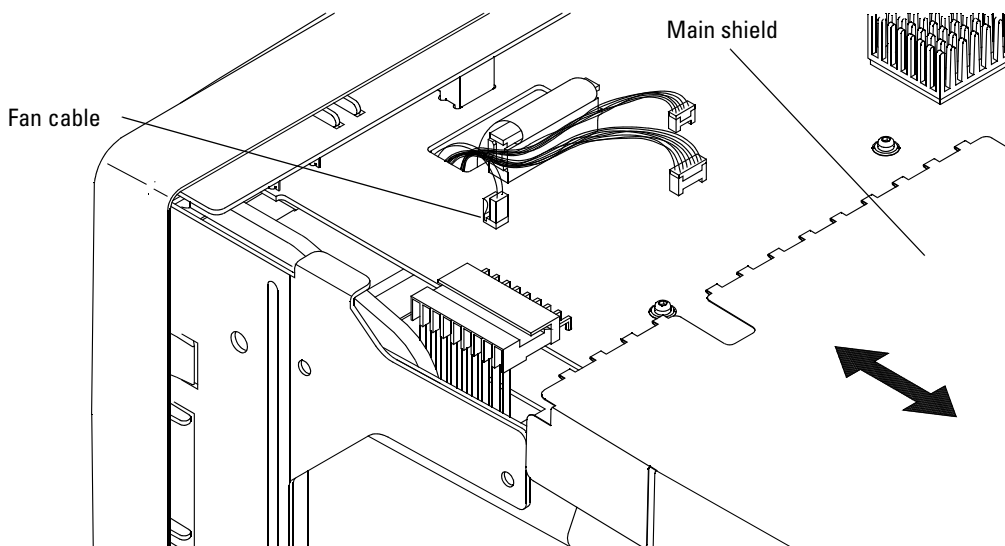

Figure 42 Removing main shield and disconnecting fan cable.

- 4** Slide the fan mount to the side to remove the 4 retainer hooks from their keyholes and lift out.

It may help to push on each of the hooks to keep from tearing them.

- 5** Peel the rubber fan mount off the corners of the fan.

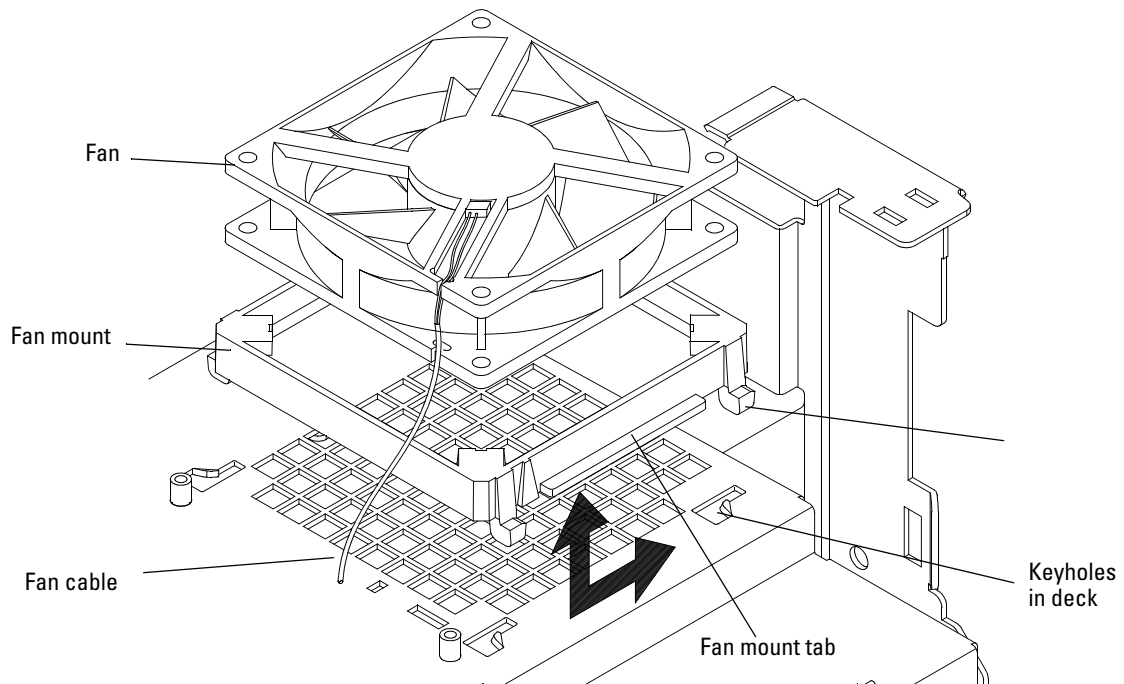

Figure 43 Removing the fan

- 6** Reverse this procedure to replace the fan assembly.
- When reinstalling, note the position of the tab on the fan mount and the direction of the fan cable.
 - Ensure that the assembly is locked into the keyholes

To remove the system board

- 1 Perform the previous procedures:
 - “To remove the cabinet” on page 87
- 2 Remove the main shield covering the system board by sliding it toward the back of the instrument.

WARNING

Thin sheet metal parts may have sharp edges. Handle with care to avoid injury.

- 3 Using a small flat blade screw driver, gently pry and remove the display cable and backlight inverter cable.
- 4 Disconnect the fan cable and keyboard ribbon cable then push all cables back through the hole in the system board.

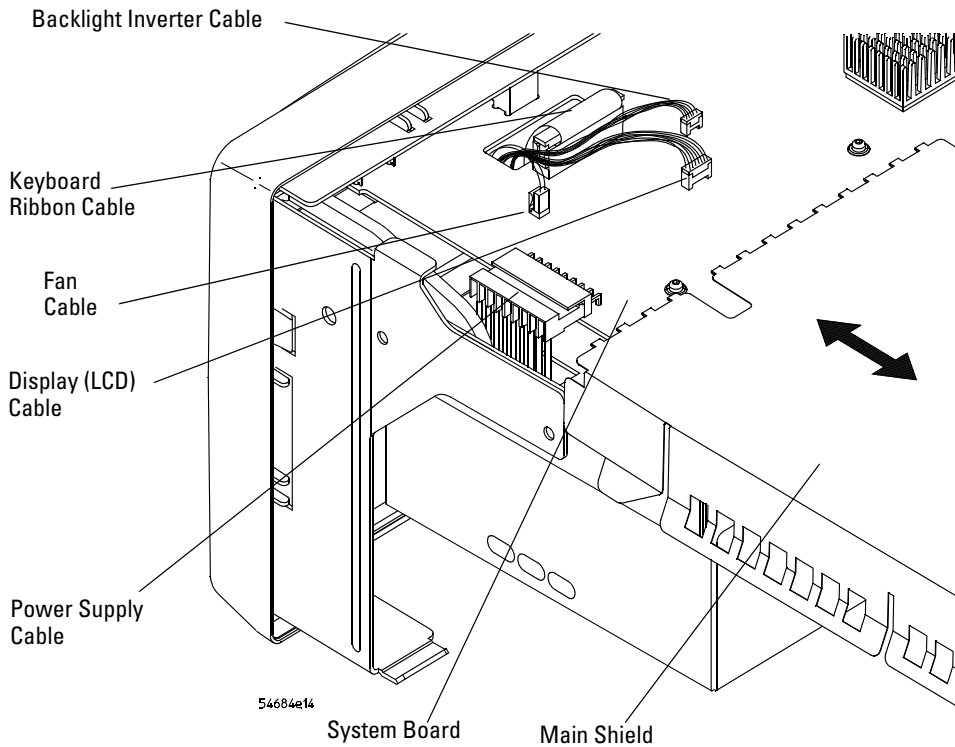

Figure 44 Preparing to remove the system board

- 5** Disconnect the power supply cable.
- 6** Remove the intensity knob by grasping the knob with one hand and gently prying using a flat-blade screwdriver with the other hand.

Using a twisting motion with the screwdriver rather than prying prevents marking or damaging the front panel.
- 7** Remove the 3 or 4 T6 screws located by the BNCs on the front panel (see [Figure 20](#) on [page 90](#)).
- 8** Remove the three hex nuts and washers from the rear BNCs using the 5/8-inch socket driver.
- 9** Using the 9/32 hex driver, remove two hex standoffs and washers from GPIB connector.

10 Using the T10 TORX driver, remove the five screws that hold the system board to the deck.

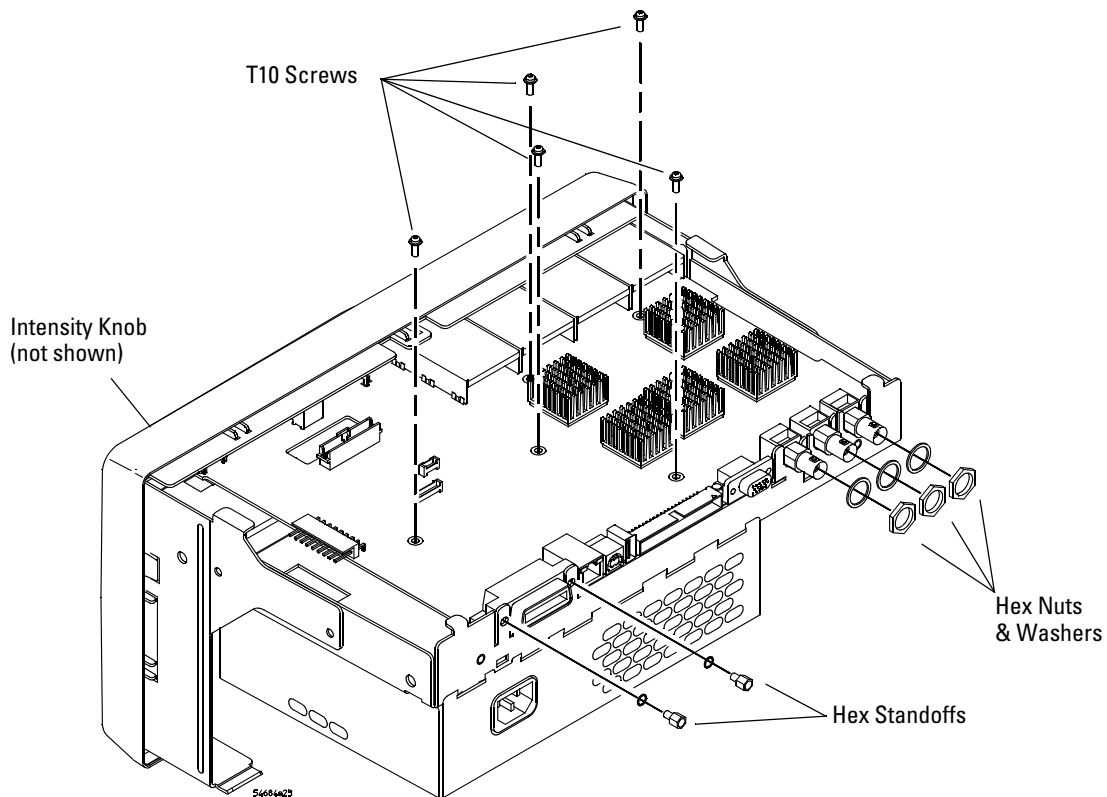
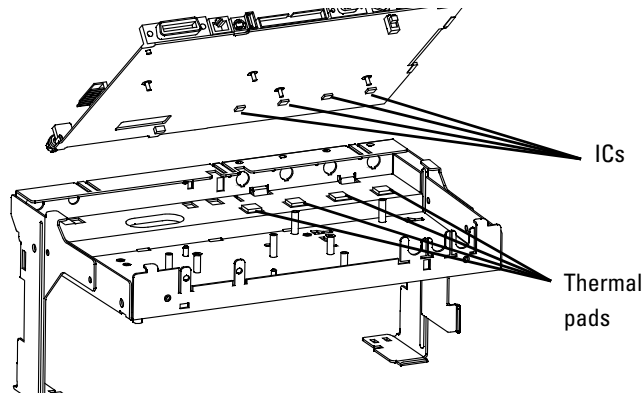

Figure 45 Removing the system board

11 Lift the back of the board to clear the main deck and then gently pull the board straight out.

CAUTION

To avoid tearing the thermal pads (on MS0/DS0601xA models) when removing or installing the system board, hold the board up, away from the thermal pads until the BNCs and other components are clear.

**12** To reinstall the system board:

- a** Insert the tabs on the board into the slots in the front of the sheet metal; the intensity shaft, BNCs, and CAL lug into their holes.
- b** Push the back of the board down to seat.
- c** Reinstall the T6 screws on the front panel (shown in [Figure 20](#) on [page 90](#)).
- d** Reinstall the GP-IB hex standoffs, BNC hex nuts and washers, and then the five T10 screws.
- e** Reconnect the cables.
- f** Ensure that the backlight, fan, and LCD cables are routed to the left of the keyboard ribbon cable as shown in [Figure 44](#) on [page 117](#).
- g** Replace the intensity knob by supporting the back of the encoder and pushing the knob fully onto the shaft.

5 Replacing Assemblies



6 Replaceable Parts

This chapter describes how to order replaceable assemblies and parts for the Agilent 6000 Series Oscilloscopes.

Diagrams and parts lists are included for assemblies and hardware that you can order.

Before working on the oscilloscope, read the safety summary at the back of this book.



Ordering Replaceable Parts

Listed Parts

To order a part in the parts list, quote the Agilent Technologies part number, indicate the quantity desired, and address the order to the nearest Agilent Technologies Sales Office. To find your nearest sales office go to **www.agilent.com**.

Unlisted Parts

To order a part not listed in the parts list, include the instrument part number, instrument serial number, a description of the part (including its function), and the number of parts required. Address the order to the nearest Agilent Technologies Sales Office.

Direct Mail Order System

Within the USA, Agilent Technologies can supply parts through a direct mail order system. There are several advantages to this system:

- Direct ordering and shipping from the Agilent Technologies parts center in California, USA.
- No maximum or minimum on any mail order. (There is a minimum amount for parts ordered through a local Agilent Technologies Sales Office when the orders require billing and invoicing.)
- Prepaid transportation. (There is a small handling charge for each order.)
- No invoices.

In order for Agilent Technologies to provide these advantages, please send a check or money order with each order.

Mail order forms and specific ordering information are available through your local Agilent Technologies Sales Office. Addresses and telephone numbers are located in a separate document shipped with the manuals.

Exchange Assemblies

Some parts used in this instrument have been set up for an exchange program. This program allows the customer to exchange a faulty assembly with one that has been repaired, calibrated, and performance-verified by the factory. The cost is significantly less than that of a new part. The exchange parts have a part number in the form XXXXX-695XX.

After receiving the repaired exchange part from Agilent Technologies, a United States customer has 30 days to return the faulty assembly. For orders not originating in the United States, contact the local Agilent Technologies service organization. If the faulty assembly is not returned within 30 days, the customer will be charged an additional amount. The additional amount will be the difference in price between a new assembly and that of an exchange assembly.

Exploded Views

The following exploded views provide a graphical representation of the oscilloscope at the time this manual was released. Not all parts are shown. Your parts may be slightly different than those shown. These views provide reference designator numbers that map to those used in the parts list table in this chapter.

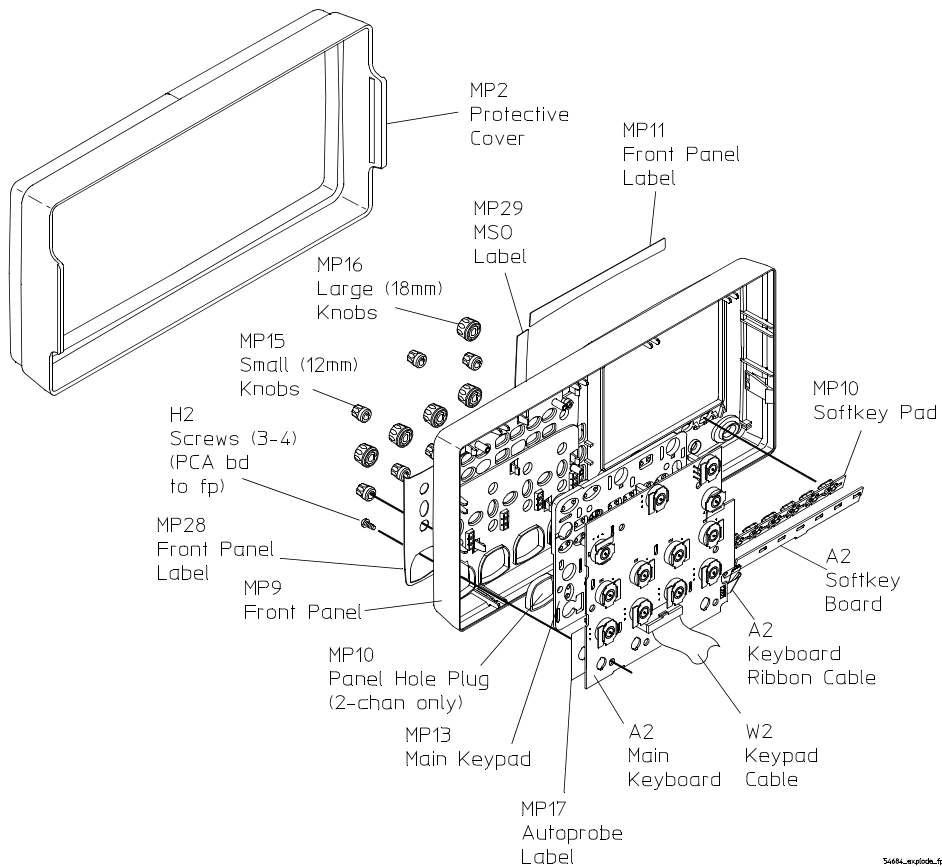

5468a_explo01a.jp

Figure 46 Exploded View 1 of 2

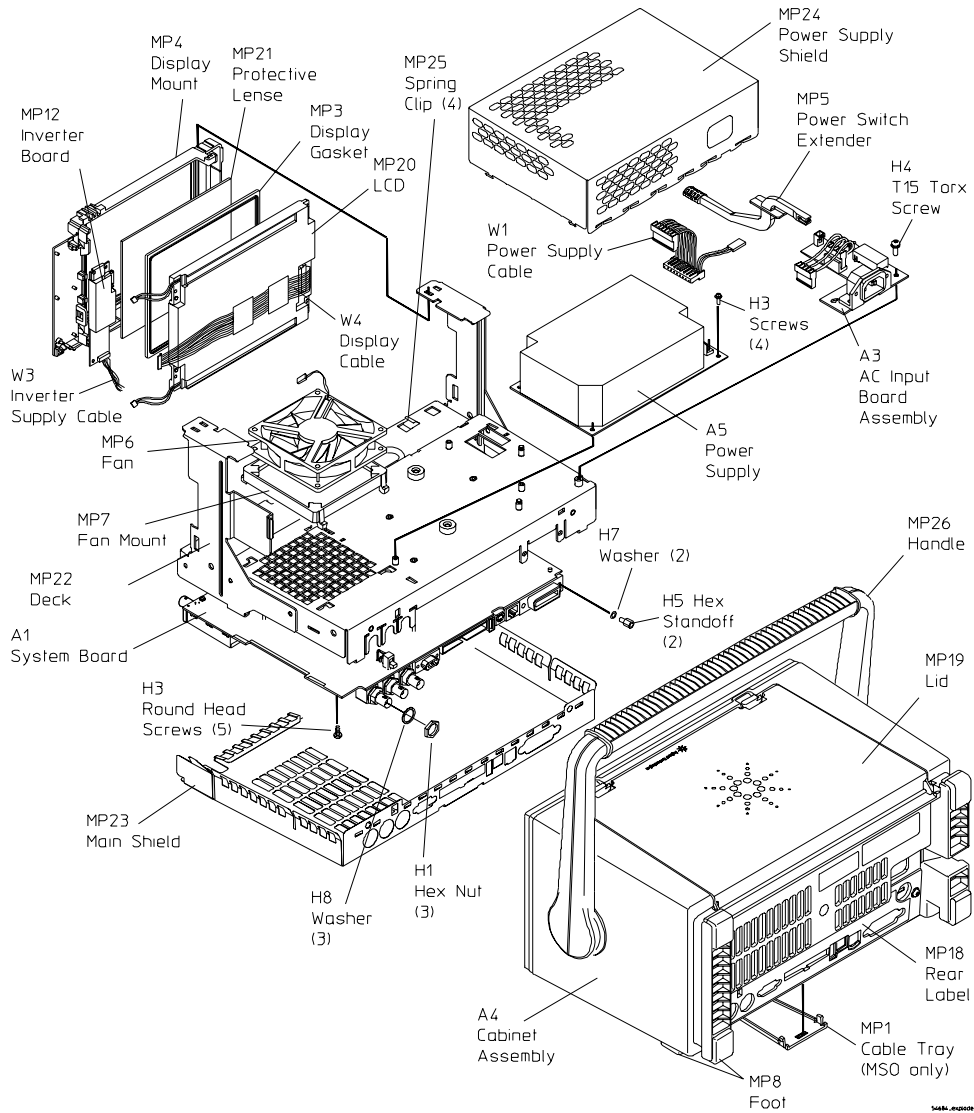

Figure 47 Exploded View 2 of 2

Replaceable Parts List

The information given for each part consists of the following:

- Reference designation.
- Agilent Technologies part number.
- Total quantity (QTY) in the instrument or on assembly.
- Description of the part.

Table 15 Replaceable Parts

Ref Des	Agilent Part Number	Qty	Description
A1	54632-66501	1	2-ch 100 MHz system board
A1	54634-66501	1	4-ch 100 MHz system board
A1	54662-66506	1	2-ch 300 MHz system board
A1	54664-66506	1	4-ch 300 MHz system board
A1	54672-66506	1	2-ch 500 MHz system board
A1	54674-66506	1	4-ch 500 MHz system board
A1	54682-66506	1	2-ch 1 GHz system board
A1	54684-66506	1	4-ch 1 GHz system board
A2	54682-66511	1	2-ch keyboard assembly
A2	54684-66511	1	4-ch keyboard assembly
A3	54684-66516	1	AC line filter/power switch PC board assembly
A4	54684-64401	1	Cabinet assembly
A5	0950-4664	1	Power Supply
H1	2950-0054	3	Hex Nut - 1/2-28 thd
H2	0515-0658	4	Screw - machine m2 x 0.4 - 6 mm lg T6 - w/washer

Ref Des	Agilent Part Number	Qty	Description
H3	0515-0372	9	Screw - machine m3 x 0.5 - 8 mm lg T10 - w/washer
H4	0515-0380	3	Screw - machine m4 x 0.7 - 10 mm lg T15 - w/washer
H5	0380-0643	2	Standoff - hex 0.255 in. lg 6-32 thd
H6	2190-0068	3	Washer - internal tooth lock 0.505 in. id
H7	2190-0009	2	Washer - internal tooth lock 0.168 in. id
MP1	54684-42301	1	Cable tray/guide - MSO only
MP2	54684-44101	1	Cover, protective front
MP3	54684-47101	1	Display gasket
MP4	54684-44702	1	Display mount
MP5	54684-43901	1	Extender, power switch
MP6	54684-68501	1	Fan
MP7	54684-44701	1	Fan mount
MP8	54684-41001	6	Foot pad
MP9	54684-60201	1	Front panel
MP10	54684-42202	1	Hole plug front panel - 2 ch only
MP11	54632-94301	1	ID label 2-ch 100 MHz DSO
MP11	54632-94302	1	ID label 2-ch 100 MHz MSO
MP11	54634-94301	1	ID label 4-ch 100 MHz DSO
MP11	54634-94302	1	ID label 4-ch 100 MHz MSO
MP11	54662-94301	1	ID label 2-ch 300 MHz DSO
MP11	54662-94302	1	ID label 2-ch 300 MHz MSO
MP11	54664-94301	1	ID label 4-ch 300 MHz DSO

6 Replaceable Parts













Ref Des	Agilent Part Number	Qty	Description
MP11	54664-94302	1	ID label 4-ch 300 MHz MSO
MP11	54672-94301	1	ID label 2-ch 500 MHz DSO
MP11	54672-94302	1	ID label 2-ch 500 MHz MSO
MP11	54674-94301	1	ID label 4-ch 500 MHz DSO
MP11	54674-94302	1	ID label 4-ch 500 MHz MSO
MP11	54682-94301	1	ID label 2-ch 1 GHz DSO
MP11	54682-94302	1	ID label 2-ch 1 GHz MSO
MP11	54684-94301	1	ID label 4-ch 1 GHz DSO
MP11	54684-94302	1	ID label 4-ch 1 GHz MSO
MP12	0950-4438	1	Inverter, dual backlight
MP13	54684-41901	1	Keypad, main
MP14	54684-41902	1	Keypad, softkey
MP15	54801-47401	4	Knob - 12 mm flint gray
MP15	54801-47404	1	Knob - 12 mm yellow
MP15	54801-47405	1	Knob - 12 mm green
MP15	54801-47406	1	Knob - 12 mm purple
MP15	54801-47407	1	Knob - 12 mm pink
MP16	54801-47402	1	Knob - 18 mm gray
MP16	54801-47408	1	Knob - 18 mm yellow
MP16	54801-47409	1	Knob - 18 mm green
MP16	54801-47410	1	Knob - 18 mm purple
MP16	54801-47411	1	Knob - 18 mm pink

Ref Des	Agilent Part Number	Qty	Description
MP17	54634-94304	1	Label, autoprobe, 100 MHz models
MP17	54684-94307	1	Label, autoprobe, 300 MHz, 500 MHz, 1 GHz models
MP18	54682-94304	1	Label rear 2 ch
MP18	54684-94304	1	Label rear 4 ch
MP19	54684-40301	1	Lid, storage compartment
MP20	2090-0881	1	Liquid crystal display
MP21	54684-88001	1	Protective lens
MP22	54684-00101	1	Deck
MP23	54684-00601	1	Shield, main
MP24	54684-00602	1	Shield, power supply
MP25	0363-0313	4	Spring clips
MP26	54684-44901	1	Handle
MP27	54684-00604		E-field shield (not shown)
MP28	54632-94303	1	Label, front panel, 2-channel 100 MHz
MP28	54634-94303	1	Label, front panel, 4-channel 100 MHz
MP28	54682-94305	1	Label, front panel, 2-ch 300 MHz, 500 MHz, 1 GHz
MP28	54684-94305	1	Label, front panel, 4-ch 300 MHz, 500 MHz, 1 GHz
MP29	54684-94306	1	Label, MSO
W1	54684-61607	1	Cable, DC
W2	54684-61601	1	Cable, keyboard
W3	54684-61602	1	Inverter supply cable
W4	54684-61603	1	LVDS display cable

6 Replaceable Parts

Ref Des	Agilent Part Number	Qty	Description
W5	8120-1703	0-1	Power cord option 900 3-COND 2-M-LG 13A-FUS
W5	8120-0696	0-1	Power cord option 901, Australia
W5	8120-1692	0-1	Power cord option 902, Europe
W5	8120-1521	0-1	Power cord option 903, U.S.A.
W5	8120-2296	0-1	Power cord option 906, Switzerland
W5	8120-2957	0-1	Power cord option 912, Denmark
W5	8120-4600	0-1	Power cord option 917, Africa
W5	8120-4754	0-1	Power cord option 918, Japan
W5	8120-6799	0-1	Power cord option 919, Israel
W5	8120-6871	0-1	Power cord option 920, Argentina
W5	8120-6979	0-1	Power cord option 921, Chile
W5	8120-8377	0-1	Power cord option 922, China
W5	8120-8871	0-1	Power cord option 927, Thailand
	54620-61801	0-1	Cable assembly, logic
	10073C	2-4	Passive Probe 10:1, 500 MHz
	10074C	2-4	Passive Probe 10:1, 150 MHz
	5090-4833	0-1	Grabber kit assembly
	5959-9334	1	Probe grounds, 2-inch, quantity 5

Table 16 Power Cords

Plug Type	Cable Part Number	Plug Type	Cable Part Number
Opt 900 (U.K.) 	8120-1703	Opt 918 (Japan) 	8120-4754
Opt 901 (Australia) 	8120-0696	Opt 919 (Israel) 	8120-6799
Opt 902 (Europe) 	8120-1692	Opt 920 (Argentina) 	8120-6871
Opt 903 (U.S.A.) 	8120-1521	Opt 921 (Chile) 	8120-6979
Opt 906 (Switzerland) 	8120-2296	Opt 922 (China) 	8120-8377
Opt 912 (Denmark) 	8120-2957	Opt 927 (Thailand) 	8120-8871
Opt 917 (Africa) 	8120-4600		

Index

A

AC input board removal, 113
assemblies
 exchange, 123
 replacing, 85

B

backlight inverter removal, 100
bandwidth
 verification, 40

C

cabinet, removing, 87
calibration, 61
cautions, 69, 70, 78, 86, 112
certificate of calibration, 61
channels
 problem solving, 67
characteristics, 15
cleaning the instrument, 135
compensating your probe, 73
connecting for threshold test, 33

D

digital channel
 testing, 30
 verification, 31
display
 assembly removal, 96
 problem solving, 66

E

equipment, test, 26
exchange assemblies, 123

exploded view
 front panel, 124
 instrument, 125

F

fan removal, 114
Fluke MET/CAL procedures, 27
front panel
 exploded view, 124
 removal, 90
fuse, 80

G

graber kit, 130
grounds, probe, 130

H

handle, removing, 88
horizontal
 accuracy verification, 45

I

internal self-tests, 83

K

keyboard, removal, 93
knobs, 128

L

LCD removal, 104
LED, startup sequence, 70
lid, removal, 89
logic cable assembly, 130

M

making test connector, 28
measurement accuracy, voltage, 35

N

NIST, 61

O

ordering parts, 122

P

parts
 list, 126
 ordering, 122
passive probe, 130
perform user cal, 61
performance
 test record, 56
power
 cord list, 130
 supply removal, 111
 supply shield, removal, 107
 switch removal, 112
 test points, 79
probe grounds, 130
probes
 compensating, 73
 problem solving, 65

R

record tests, 56

Index

remove
AC input board, 113
backlight inverter, 100
cabinet, 87
display assembly, 96
fan, 114
front panel, 90
handle, 88
keyboard, 93
LCD, 104
power supply, 111
power supply shield, 107
power switch, 112
softkey pad, 93
storage lid, 89
system board, 116
replaceable parts list, 126
replacing assemblies, 85
run self-tests, 83

S

safety notice, 59, 69
self-alignment, user cal, 61
self-tests, 83
softkey pad, removal, 93
specifications, 14
startup sequence, 70
status, User Cal, 64
status, user cal, 61
storage lid, removal, 89
system board
part number, 126
removal, 116

T

test
connector,constructing, 28
digital channels, 30
equipment, 26
points, power, 79
record, 56

threshold
accuracy,digital channel, 31
test,diagram, 33
trace display
problem solving, 66, 67
trigger
sensitivity, 47
sensitivity,external, 50, 54
sensitivity,internal, 49
troubleshooting, 65
display, 81
equipment required, 70
fan, 82
flowcharts, 73
power supply, 78

U

user calibration, 61

V

verify
bandwidth, 40
digital channel, 31
horizontal accuracy, 45
trigger, 47
voltage measurement accuracy, 35

W

warnings, 86, 107
warranted specifications, 14

Safety Notices

This apparatus has been designed and tested in accordance with IEC Publication 1010, Safety Requirements for Measuring Apparatus, and has been supplied in a safe condition. This is a Safety Class I instrument (provided with terminal for protective earthing). Before applying power, verify that the correct safety precautions are taken (see the following warnings). In addition, note the external markings on the instrument that are described under "Safety Symbols."

Warnings

Before turning on the instrument, you must connect the protective earth terminal of the instrument to the protective conductor of the (mains) power cord. The mains plug shall only be inserted in a socket outlet provided with a protective earth contact. You must not negate the protective action by using an extension cord (power cable) without a protective conductor (grounding). Grounding one conductor of a two-conductor outlet is not sufficient protection.

Only fuses with the required rated current, voltage, and specified type (normal blow, time delay, etc.) should be used. Do not use repaired fuses or short-circuited fuseholders. To do so could cause a shock or fire hazard.

If you energize this instrument by an auto transformer (for voltage reduction or mains isolation), the common terminal must be connected to the earth terminal of the power source.

Whenever it is likely that the ground protection is impaired, you must make the instrument inoperative and secure it against any unintended operation.

Service instructions are for trained service personnel. To avoid dangerous electric shock, do not perform any service unless qualified to do so. Do not attempt internal service or adjustment unless another person, capable of rendering first aid and resuscitation, is present.

Do not install substitute parts or perform any unauthorized modification to the instrument.

Capacitors inside the instrument may retain a charge even if the instrument is disconnected from its source of supply.

Do not operate the instrument in the presence of flammable gasses or fumes. Operation of any electrical instrument in such an environment constitutes a definite safety hazard.

Do not use the instrument in a manner not specified by the manufacturer.

To clean the instrument

If the instrument requires cleaning: (1) Remove power from the instrument. (2) Clean the external surfaces of the instrument with a soft cloth dampened with a mixture of mild detergent and water. (3) Make sure that the instrument is completely dry before reconnecting it to a power source.

Safety Symbols



Instruction manual symbol: the product is marked with this symbol when it is necessary for you to refer to the instruction manual in order to protect against damage to the product..



Hazardous voltage symbol.



Earth terminal symbol: Used to indicate a circuit common connected to grounded chassis.